

## Operating manual

(Translation of the original instructions)

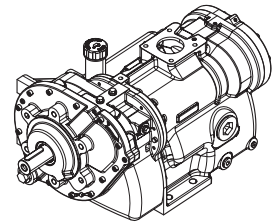
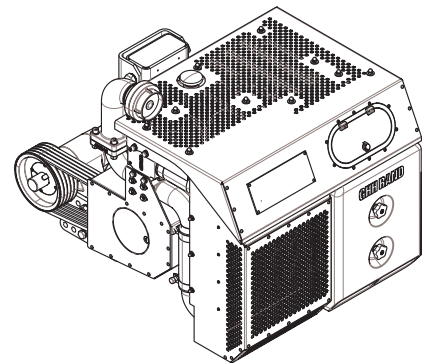
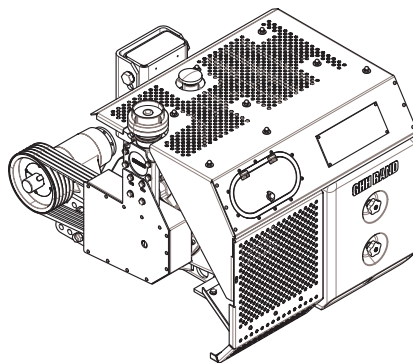
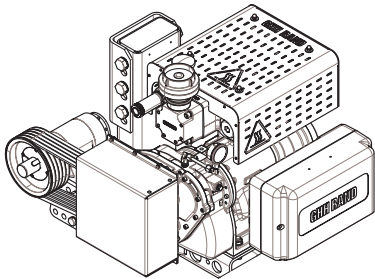

SILU CS80  
SILU CS700 LITE  
SILU CS700 STANDARD  
SILU CS700 IC

**DE WICHTIG!**

Die Betriebsanleitung liegt in Ihrer Landessprache zusammen mit der Montageanleitung (englische und deutsche Ausführung) elektronisch auf der Webseite [www.ingersoll.com/ghhrandtransport](http://www.ingersoll.com/ghhrandtransport) für den Download bereit. Auf Anfrage senden wir Ihnen auch gerne eine gedruckte Version zu.

**EN IMPORTANT!**

The operating instructions can be downloaded electronically in your language, together with the mounting instructions (in English and German) from the website [www.ingersollrand.com/ghhrandtransport](http://www.ingersollrand.com/ghhrandtransport). On request, we will gladly send you a printed version.

**CZ DŮLEŽITÉ!**

Návod k provozu je k dispozici ke stažení v jazyce Vaší dané země společně s návodem pro montáž (anglická nebo německá verze) elektronicky na webové stránce [www.ingersollrand.com/ghhrandtransport](http://www.ingersollrand.com/ghhrandtransport). Na vyžádání vám rádi zašleme i tištěnou verzi.

**FR IMPORTANT !**

Vous pouvez télécharger la manuel d'utilisation dans la langue de votre pays avec les instructions de montage (en anglais et en allemand) au format électronique sur le site web [www.ingersollrand.com/ghhrandtransport](http://www.ingersollrand.com/ghhrandtransport). Sur demande, nous vous enverrons volontiers une version imprimée.

**NL BELANGRIJK!**

De gebruikshandleiding kan samen met de montagehandleiding (Engelse en Duitse versie) in uw taal elektronisch worden gedownload van de website [www.ingersollrand.com/ghhrandtransport](http://www.ingersollrand.com/ghhrandtransport). Op aanvraag sturen we u met alle plezier ook een gedrukte versie.

**PL WAŻNE!**

Instrukcja obsługi dostępna jest w odczystym języku użytkownika wraz z instrukcją montażu (w języku angielskim i niemieckim) w elektronicznej formie do pobrania na stronie internetowej [www.ingersollrand.com/ghhrandtransport](http://www.ingersollrand.com/ghhrandtransport). Na życzenie chętnie prześlemy Państwu również wersję drukowaną.

**RO IMPORTANT!**

Instrucțiunile de exploatare în limba țării dvs., împreună cu instrucțiunile de montaj (versiunea în limba engleză și germană) sunt disponibile pentru descărcare în format electronic pe site-ul web [www.ingersollrand.com/ghhrandtransport](http://www.ingersollrand.com/ghhrandtransport). De asemenea, la cerere vă putem trimite o versiune tipărită.

**HU FONTOS!**

Az üzemeltetési útmutató az Ön nyelvén a szerelési útmutatóval (angol és német nyelvű változat) együtt elektronikusan letölthető a [www.ingersollrand.com/ghhrandtransport](http://www.ingersollrand.com/ghhrandtransport) webhelyről. Kérésére szívesen küldünk egy kinyomtatott változatot is.

**BY ВАЖНА!**

Электронную версію кіраўніцтва па эксплуатацыі на нацыянальнай мове разам з інструкцыяй па мантажы (на англійскай і нямецкай мовах) можна спампаваць на сайце [www.ingersollrand.com/ghhrandtransport](http://www.ingersollrand.com/ghhrandtransport). Па асобным запыце мы з задавальненнем дашлем вам друкаваную версію.

## SI POMEMBNO!

Navodila za uporabo so v elektronski obliki na voljo za prenos v vašem lokalnem jeziku skupaj z navodili za montažo (angleška in nemška različica) na spletni strani [www.ingersollrand.com/ghhrandtransport](http://www.ingersollrand.com/ghhrandtransport). Na zahtevo vam bomo z veseljem poslali tudi tiskano različico.

## LT SVARBU!

Elektroninę eksploataavimo instrukcijos Jūsų šalies kalba versiją kartu su montavimo instrukcija (anglų ir vokiečių kalbomis) galite atsisiųsti iš interneto svetainės [www.ingersollrand.com/ghhrandtransport](http://www.ingersollrand.com/ghhrandtransport). Jei pateiksite užklausą, mielai atsisiųsime ir išspausdintą versiją.



## Introduction

Before installing and commissioning the SILU CS80 screw compressor or the SILU CS700 LITE, SILU CS700 STANDARD, SILU CS700 IC compressor units, please read through these operating instructions carefully (the additional designation SILU is not used in the rest of these operating instructions).

The operating manual contains important instructions which must be strictly followed if trouble-free operation and a long service life are to be ensured.

### Scope of application of the operating manual

These operating instructions only contain instructions for the above-mentioned screw compressor and the above-mentioned screw compressor units. These operating instructions are not valid for operation of a compressor unit completed by an external installer.

### Target group

The operating manual is intended for use by qualified specialist staff only.

### Notes and safety instructions

The following instructions and safety instructions are used in the operating manual to warn of dangers which could lead to operating errors, injuries and tangible damage:

#### **DANGER**

DANGER warns of an imminent danger and indicates an imminent danger. This safety note warns of possible irreversible to fatal injuries.

#### **WARNING**

WARNING indicates a possible imminent danger. This safety note warns of serious or perilous injuries.

#### **CAUTION**

CAUTION indicates a possible imminent danger. This safety note warns of light injuries.

#### **NOTICE**

ATTENTION warns of possible tangible damage or malfunctions.

#### **NOTE**

NOTES contain instructions to prevent operating errors and other specific useful or important information.

## Contents

<b>1</b>	<b>GENERAL</b> .....	<b>7</b>
1.1	Application .....	7
1.2	Manufacturer's address .....	7
1.3	Identification.....	7
1.4	Information for enquiries and orders .....	7
1.5	Service & Support .....	7
1.6	Technical data CS80 screw compressor.....	8
1.7	Technical data CS700 compressor units.....	9
1.8	Operating the compressor at high altitudes.....	10
1.9	Lubricant .....	10
1.10	Screw compressor type plate.....	11
1.11	Compressor unit type plate.....	11
<b>2</b>	<b>SAFETY</b> .....	<b>12</b>
2.1	General.....	12
2.2	Authorised personnel, training and qualification.....	12
2.3	Safety-conscious work.....	12
2.4	Safety instructions for the owner/operator .....	12
2.5	Unauthorised conversions and spare parts.....	13
2.6	Incorrect operating methods.....	13
2.7	Disposal.....	13
<b>3</b>	<b>OPERATION</b> .....	<b>14</b>
3.1	Safety during operation .....	14
3.2	Initial commissioning .....	14
3.3	Installation .....	15
3.4	Switching on .....	15
3.5	Monitoring operation.....	16
3.5.1	CS80/external installation .....	16
3.5.2	CS700 LITE.....	16
3.5.3	CS700 IC .....	18
3.6	External oil cooler for compressor (optional) .....	19
3.6.1	Function control of external oil cooler fan .....	19
3.7	Switching off .....	20
3.8	Preservation .....	20
<b>4</b>	<b>MAINTENANCE/REPAIR</b> .....	<b>21</b>
4.1	Safety.....	21
4.2	Observe the tightening torques .....	21
4.3	Maintenance Intervals.....	22
4.4	Maintenance work.....	23
4.4.1	Readjusting the tension of the V-belts and quick-release bushings of the V-belt pulleys .....	23
4.4.2	Retightening the fastening screws on the discharge silencer .....	24
4.4.3	Checking the oil level.....	25
4.4.4	Cleaning and replacing the intake filter element .....	26
4.4.5	Check the safety valve .....	26
4.4.6	Check the non-return valve.....	27
4.4.7	Testing and cleaning the air cooler .....	28
4.4.8	Oil change and cleaning the oil intake strainer .....	28

**5 FAULTS, CAUSE AND INSTRUCTIONS FOR TROUBLESHOOTING .....30**

## 1 General

### 1.1 Application

GHH RAND builds and supplies the CS80 screw compressor and the CS700 screw compressor unit.

Because of their oil-free compression of atmospheric air and their power-to-weight ratio for installation on silo vehicles, the compressor unit is used to pneumatically convey bulk goods, such as flour, sugar, salt, animal feed, powdered chemicals, dry granulate, soda, cement, sand, lime, plaster, etc.

The products built and supplied by GHH RAND are only designed for the operation at and on utility vehicles that exclusively drive on paved roads.

A different use requires the consultation with the manufacturing plant.

### 1.2 Manufacturer's address

GHH RAND  
Schraubenkompressoren GmbH  
Max-Planck-Ring 27  
46049 Oberhausen

### 1.3 Identification

For the machine data, refer to the accompanying documents and the rating plate.

In order to always have the data on hand, we recommend that you enter it into the following blank space.

Compressor serial no.:

Unit serial no.:

### 1.4 Information for enquiries and orders

If you have enquiries or orders for spare parts and accessories, please provide details of the exact type designation and the serial number of the screw compressor or the compressor unit, for which the spare part or accessory is intended.

#### CAUTION

##### **USE OF UNAUTHORISED SPARE PARTS AND ACCESSORIES!**

Original replacement parts and accessories that are authorised by the manufacturer represent safety factors. The use of non-original or non-authorized replacement parts and accessories may void the liability for the resulting consequences.

- ▶ Only use original spare parts and accessories authorised and approved by the manufacturer.

### 1.5 Service & Support

[www.ingersollrand.com/ghhrandtransport](http://www.ingersollrand.com/ghhrandtransport)

## 1.6 Technical data CS80 screw compressor

Dimensions & weight			Rotational speed range	
Length (approx.)	mm	640	min. rpm	1000
Width (approx.)	mm	392	max. rpm	2000
Height (approx.)	mm	345		
Weight (approx.)	kg	146		
Maximum operating pressure			Oil filling quantity	
max. 2.5 bar			approx. 9 litres	
Maximum intake negative pressure			Minimum oil pressure	
max. 65 mbar			min. 0.3 bar	

Performance data	Unit	CS80		
Rotary valve compressor	rpm	1000	1500	2000
<b>Operating overpressure</b>	<b>bar</b>	<b>1.5</b>		
Intake volume	m <sup>3</sup> /h	292	512	725
Coupling output	kW	16.4	25.6	35.4
Final temperature	°C	165	151	153
Intake temperature max.	°C	50	50	50
Intake temperature min.	°C	-20	-20	-20
<b>Operating overpressure</b>	<b>bar</b>	<b>2.0</b>		
Intake volume	m <sup>3</sup> /h	279	500	713
Coupling output	kW	19.9	30.4	41.4
Final temperature	°C	207	181	180
Intake temperature max.	°C	44	50	50
Intake temperature min.	°C	-20	-20	-20
<b>Operating overpressure</b>	<b>bar</b>	<b>2.5</b>		
Intake volume	m <sup>3</sup> /h	265	487	701
Coupling output	kW	23.5	35.3	47.6
Final temperature	°C	254	214	208
Intake temperature max.	°C	23	40	42
Intake temperature min.	°C	-20	-20	-20

### All information for:

Feed medium: atmospheric air

Intake pressure: 1 bar (abs.)

Intake temperature: 20 °C

Technical data without intake or pressure losses



## 1.7 Technical data CS700 compressor units

Dimensions & weight		CS700 LITE	CS700 STANDARD	CS700 IC
Width (approx.)	mm	785	800	800
Depth (approx.)	mm	715	780	830
Height (approx.)	mm	745	745	835
Weight (approx.)	kg	318	371	400

Speed range at standard ratio*	Unit	CS700 units		
Compressor unit drive speed	rpm	800	1200	1600
V-belt drive transmission ratio (standard)			1.25	
CS80 compressor rotational speed	rpm	1000	1500	2000

\* Transmission ratio may vary. Several V-belt drives are available from the factory for the transmission ratio (adjustable to the auxiliary drive installed in the vehicle).

### NOTICE

#### DAMAGE TO THE COMPRESSOR!

Exceeding the permitted speed range leads to material damage.

- ▶ Do not operate the compressor outside of its permitted speed range.

#### Maximum operating pressure

max. 2.5 bar

#### Oil filling quantity

approx. 9 litres

#### Maximum intake negative pressure

max. 65 mbar

#### Minimum oil pressure

min. 0.3 bar

### NOTE

The performance data of the CS700 compressor unit correspond to screw compressor CS80 (*Chapter 1.6 on page 8*).

### 1.8 Operating the compressor at high altitudes

If operating the compressor at high altitudes, make sure that, depending on the existing ambient pressure, the operating overpressure must be reduced in order to prevent temperature damage to the compressor.

This should be carried out in accordance with the following table:

Installation height h [m]	0	1000	1500	2000	2500	3000	3500	4000	4500
Permitted operating overpressure $p_{permitted}$ [bar]	2.53	2.25	2.11	1.99	1.87	1.75	1.64	1.54	1.44

**NOTICE**

**TEMPERATURE DAMAGE!**

An ambient temperature outside the permitted range can result in damage to the compressor.

- ▶ The existing ambient temperature or intake temperature must be in the range -20 °C to +23 °C.

### 1.9 Lubricant

We recommend using our fully synthetic high-performance lubricant, Silol.

If you use exclusively Silol or Silol FG (foodgrade) the interval for an oil change **doubles** to a max. **12 months**. The period of the manufacturer's warranty for new compressor units **is extended to 2 years**.

**NOTE**

For recognition of the guarantee extension, proof of the maintenance interval using Silol or Silol FG is required.

Depending on the operating conditions, brand-name motor oils with API classification SJ/CF as per SAE J183 can also be used.

The respective viscosity class (SAE class) can be taken from the following diagram.

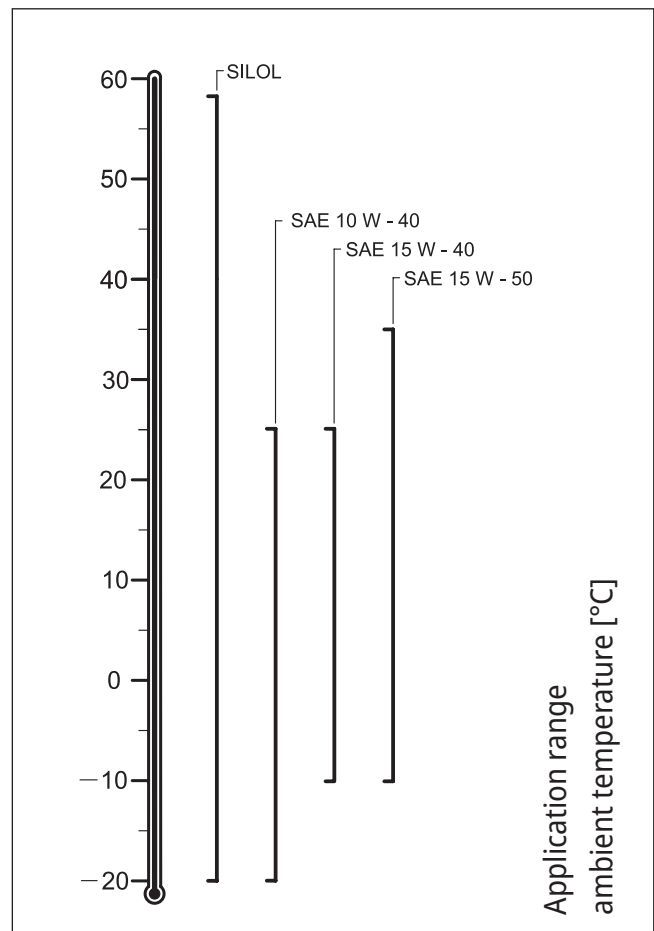

### 1.10 Screw compressor type plate

The type plate is attached to the side of the screw compressor. It contains the following information:

- Type
- Serial number
- Rotational speed range
- max. volume flow
- At max. operating pressure
- max. power consumption

**NOTE**

The complete identification has certificate value and may not be changed or rendered illegible.

### 1.11 Compressor unit type plate

The type plate on the compressor unit is attached to the mounting console.

It contains the following information:

- Type
- Year of Manufacture
- Compressor serial no.
- Unit serial no.
- V-belt drive ratio
- Unit drive speed
- Intake volume
- max. operating pressure

**NOTE**

The complete identification has certificate value and may not be changed or rendered illegible.

## 2 Safety

### 2.1 General

This operating manual contains basic instructions to be followed during operation and maintenance/repair. Therefore, this operating manual must be read by the responsible technical staff/operator prior to commissioning and it must always be available at the place of use for the screw compressor.

### 2.2 Authorised personnel, training and qualification

Work carried out on the compressor, such as operation and maintenance/repair, must only be carried out by persons with the appropriate authorisation, training and qualifications, who are familiar with the valid safety regulations.

Repairs or modifications must only be performed by authorised personnel who is available at any time at the service sites or at GHH RAND.

### 2.3 Safety-conscious work

The essential safety-related regulations for installation, operation and maintenance/repair of air compressors are contained in the following publications:

Machinery Directive 2006/42/EC

#### Standards, in particular:

DIN EN ISO 12100-1/2	Safety of machinery
DIN EN 1012-1	Compressors and vacuum pumps, safety requirements

#### The regulations of the professional associations, in particular:

BGI 666	Sample operating instructions for operation of container vehicles for granular or dust-like goods (silo vehicles).
---------	--

In this context, the respectively last applicable versions of these regulations shall be authoritative. Special legal provisions and regulations, particularly safety regulations, that may apply in your company or due to local conditions must also be adhered to. In case of competing regulations, the more restrictive provisions shall be applied. You must also observe any national regulations in the respective country of use.

### 2.4 Safety instructions for the owner/operator

The owner/operator is responsible for ensuring that the screw compressor is in a safe operational condition. Damaged or faulty parts must be immediately replaced. If the screw compressor is used to convey combustible materials, make sure that the temperature remains below the spontaneous ignition temperature for any dust/air mixture which may be created. In accordance with the professional association regulation BGI 666, for the pneumatic transport of materials subject to dust explosion, a temperature limit of max. 120 °C must be adhered to (measurement point before contact with the materials to be conveyed).

## 2.5 Unauthorised conversions and spare parts

Conversions and modifications to the screw compressor and screw compressor unit are not permitted. Damage to the seal will void any warranty claims. Original replacement parts and accessories that are authorised by the manufacturer represent safety factors. The use of non-original or unauthorised replacement and accessory parts may void the liability for resulting consequences.

## 2.6 Incorrect operating methods

### WARNING

#### **INCORRECT OPERATING METHODS!**

The operation of the compressor under incorrect conditions may lead to serious injuries and significant material damage.

- ▶ The compressor must only be operated under permitted conditions.

Unless approval is obtained from GHH RAND, the compressor must only be operated under the conditions stated in *Chapter 1.6 on page 8* to *Chapter 1.8 on page 10*.

## 2.7 Disposal

Compressor components, as well as operating materials used in conjunction with the screw compressor and compressor unit must be disposed of observing the local regulations.

## 3 Operation

### 3.1 Safety during operation

**NOTE**

Also observe the safety instructions in *Chapter 2 on page 12*.

**⚠ DANGER****RISK OF EXPLOSION!**

For the conveyance of combustible, dust-like materials, the temperature of the compressed air at the measurement point directly before contact with the material to be conveyed may not exceed the maximum value of 120 °C.

- ▶ If the maximum temperature is exceeded, switch off the compressor immediately.

**⚠ CAUTION****NOISE GENERATION!**

A greater acoustic pressure level can result in damage to hearing.

- ▶ Wear hearing protection.

**⚠ CAUTION****HOT MACHINE PARTS!**

During operation, the compressor is very hot. There is a risk of burning on hot machine parts.

- ▶ Wear protective gloves.

**NOTICE****OVERHEATING DUE TO EXCESSIVE RUNNING TIME!**

Exceeding the max. running time results in tangible damage due to overheating.

- ▶ Adhere to the max. running time: 3 hours running time and a subsequent 1 hour pause.

**NOTICE****OVERHEATING DUE TO EXCESSIVE OPERATING PRESSURE!**

Exceeding the max. operating pressure results in tangible damage due to overheating.

- ▶ Do not operate the compressor at an operating pressure of more than 2.5 bar.
- ▶ In the event of operating at high altitudes, adapt the operating pressure.
- ▶ If exceeded, switch off the compressor.

### 3.2 Initial commissioning

Initial commissioning of the compressor is usually carried out on the premises of the system manufacturer.

It includes removing the preservation, filling the oil tank and checking the direction of rotation.

### 3.3 Installation

- ▶ Park the vehicle in as level a position as possible.
- ▶ Observe the permitted inclination.

#### Permitted inclination

##### NOTICE

##### INSUFFICIENT LUBRICATION!

Excessive inclination results in irregular level of lubricant in the housing.

- ▶ Observe the maximum permitted inclination of the screw compressor during operation:
  - To the front and to the rear: 10°
  - To the right and left: 10°

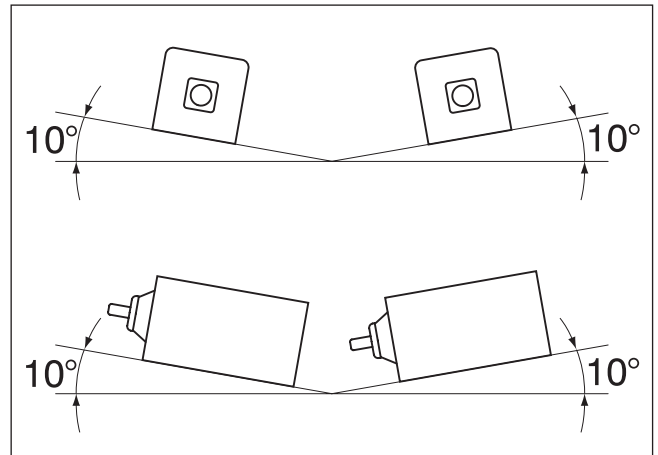

### 3.4 Switching on

##### NOTICE

##### RISK OF BLOWBACK OF MATERIAL!

If the compressor is started if there is counter pressure, there is the risk of damage to the non-return valve due to blowback of material.

- ▶ Only start the compressor when completely depressurised.
- ▶ Never go into operation against a potentially existing counter pressure.

##### NOTICE

##### INSUFFICIENT FRESH AIR SUPPLY CS700 IC!

For vehicles with side cladding installed, the side cladding must be folded down or removed before switching on the compressor unit in order to prevent temperature damage to the compressor.

- ▶ Ensure sufficient fresh air supply.

- ▶ Switch on power take-off.

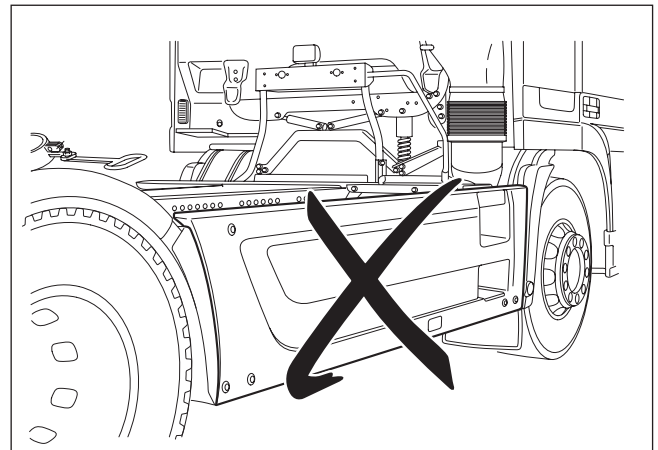

### 3.5 Monitoring operation

#### 3.5.1 CS80/external installation

The manufacturer installs a gauge (measurement position in the following pipeline) pneumatic system to monitor the compression pressure. The system manufacturer or external installer must also install displays that monitor the intake negative pressure and the oil pressure of the compressor stage. For the operation and control of the operating displays, only the instructions from the manufacturer are applicable. The permitted operating conditions and limit values can be found in *Chapter 1.6 on page 8* to *Chapter 1.8 on page 10*.

**NOTE**

With external installations, displays from diverse manufacturers can be installed. Also observe the instructions from the manufacturer.

#### 3.5.2 CS700 LITE

##### Oil pressure gauge

The oil pressure is displayed on the oil pressure gauge (1). The oil pressure may not drop below 0.3 bar.

**NOTICE**

**LOW OIL PRESSURE!**

If the oil pressure is insufficient, significant tangible damage can occur.

- ▶ Do not fall below the minimum permitted oil pressure.
- ▶ If, after a short time of operation, no oil pressure is built up, switch off the compressor and check the oil level, as necessary clean the oil intake strainer.

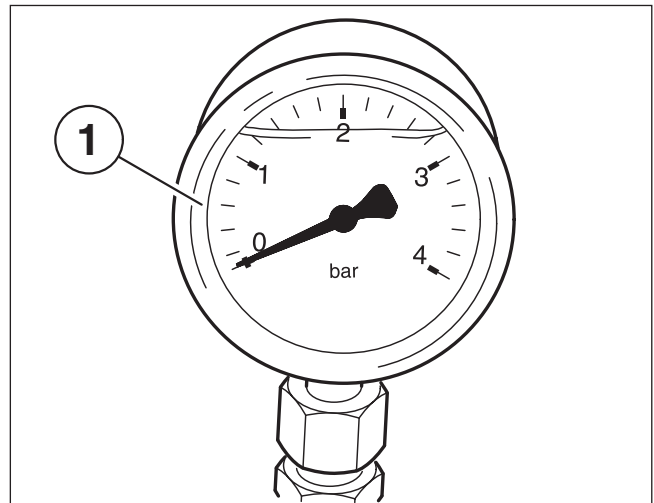

##### Maintenance indicator variant 1

The negative pressure in the compressor is displayed on the maintenance indicator (1).

The negative pressure must not exceed 65 mbar (red area on the maintenance indicator).

**NOTICE**

**PERMITTED NEGATIVE PRESSURE EXCEEDED!**

Excessive negative pressure (> 65 mbar) can result in overheating and damage to the compressor.

- ▶ Clean the intake filter elements of the compressor or, in the event of excessive clogging, replace the filter (*Chapter 4.4.4 on page 26*).

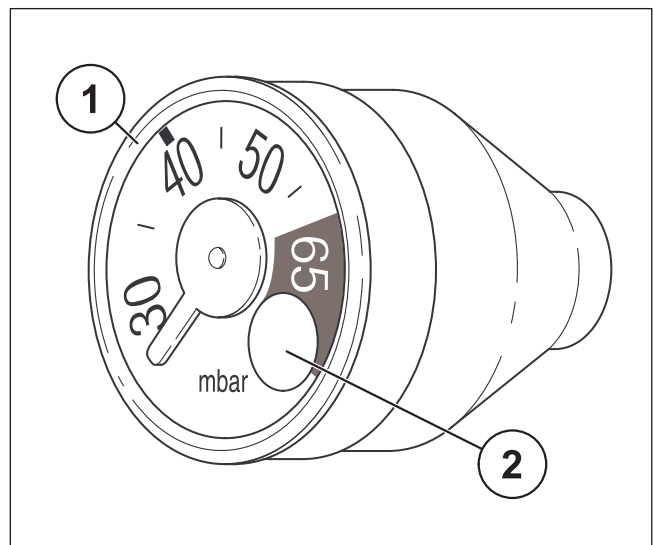



## Resetting the maintenance indicator

If the negative pressure has dropped to below the permitted limit (65 mbar, red area on the maintenance indicator), the maintenance indicator must be reset after rectification of the malfunction.

- ▶ Push the button **(2)** on the front of the maintenance indicator **(1)**.

### Maintenance indicator variant 2

The negative pressure in the compressor is displayed on the maintenance indicator **(2)**.

The negative pressure must not exceed 65 mbar. The service display **(1)** is then red.

#### NOTICE

#### PERMITTED NEGATIVE PRESSURE EXCEEDED!

Excessive negative pressure (> 65 mbar) can result in overheating and damage to the compressor.

- ▶ Clean the intake filter elements of the compressor or, in the event of excessive clogging, replace the filter (*Chapter 4.4.4 on page 26*).

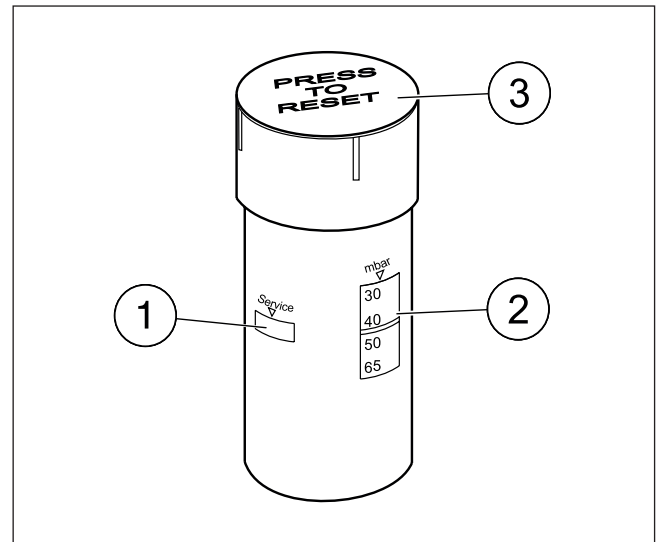

## Resetting the maintenance indicator

If the negative pressure has exceeded the permitted limit (service display **(1)** is red), the maintenance indicator must be reset after rectification of the malfunction.

- ▶ Push the button **(3)** on the top of the maintenance indicator **(2)**.

**3.5.3 CS700 IC**

1. Oil pressure display
2. Negative pressure maintenance indicator
3. Operation and fault monitoring
4. Compressed air temperature indicator
5. Cooling fan speed selector switch

Once the compressor unit has started and a compressed air temperature of 80 °C has been reached, the control unit switches on automatically.

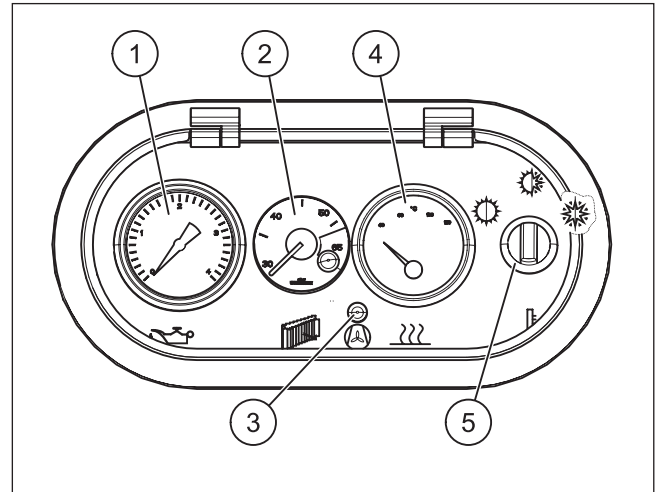
**Oil pressure display**

The oil pressure is displayed on the oil pressure gauge. The oil pressure must not reduce to below 0.3 bar.

**NOTICE****LOW OIL PRESSURE!**

If the oil pressure is insufficient, significant tangible damage can occur.

- ▶ Do not fall below the minimum permitted oil pressure.
- ▶ If, after a short time of operation, no oil pressure is built up, switch off the compressor and check the oil level, as necessary clean the oil intake strainer.

**Negative pressure maintenance indicator**

The negative pressure in the compressor is displayed on the negative pressure maintenance indicator. The negative pressure must not exceed 65 mbar (red area on the maintenance indicator).

**NOTICE****PERMITTED NEGATIVE PRESSURE EXCEEDED!**

Excessive negative pressure (> 65 mbar) can result in overheating and damage to the compressor.

- ▶ Clean the intake filter elements of the compressor or, in the event of excessive clogging, replace the filter (*Chapter 4.4.4 on page 26*).

**Resetting the maintenance indicator**

If the negative pressure has exceeded the permitted limit, the maintenance indicator must be reset after rectification of the malfunction. This is done accordingly for "Maintenance display variant 1" in *Chapter 3.5.2 on page 16*.

## Operation and fault monitoring

The operating display lights up green continuously when the compressor is operating.

### NOTICE

#### **OVERHEATING DUE TO INSUFFICIENT HEAT DISSIPATION!**

To prevent temperature damage to the compressor unit if the fan fails for emergency operation, remove the cover.

- ▶ If a sheet of paper held in front of the fan screen is not sucked towards the fan when it is running, remove the cover.

### NOTE

The operating display is switched on at an approx. final compressed air temperature of 80 °C. A fault is indicated with a flashing light.

## Compressed air temperature indicator

The compressed air temperature is measured after the cooling air outlet and indicated on the compressed air temperature indicator.

## Cooling fan speed selector switch

The fan speed can be set in three positions with the selector switch:

- Left pos.: no cooling power
- Middle pos.: medium cooling power
- Right pos.: full cooling power

## 3.6 External oil cooler for compressor (optional)

To ensure that the compressor has an optimum service life even under extreme conditions, an external oil cooler can be connected as an option.

### 3.6.1 Function control of external oil cooler fan

A sheet of paper held in front of the radiator of a running fan must be sucked towards it.

### NOTICE

#### **DAMAGE TO THE COMPRESSOR!**

The compressor can be damaged if the fan is defective.

- ▶ Check that the fan works.
  - The paper is sucked in by the fan.

### 3.7 Switching off

#### NOTICE

##### **RISK OF BLOWBACK OF MATERIAL!**

If the compressor is switched off if there is counter pressure, there is the risk of damage to the non-return valve due to blowback of material.

- ▶ Do not turn compressor off if there is counter pressure!
- ▶ If there is counter pressure, take appropriate measures to reduce pressure before switching off the compressor.

#### NOTE

The non-return valve installed in the compressor unit prevents the compressor from running backwards rapidly and for a long time (as a result of residual pressure in the compressed air lines of the pneumatic system) after being switched off.

- ▶ Switch off power take-off.

#### NOTE

Before switching off, do not manually reduce the compressor speed using the speed control.

#### NOTICE

##### **COMPRESSED AIR LINE NOT DISCONNECTED!**

The compressed air line ruptures if it is not disconnected from the compressor unit before starting the journey. Internal components of the compressor unit can also be damaged.

- ▶ Disconnect the compressed air line from the compressor unit before starting journey.

#### NOTE

After switching off the IC compressor unit, the fan of the air cooler continues to run until the air temperature in the IC unit is below 50 °C.

### 3.8 Preservation

If the compressor is shut down for an extended period of time, the compressor must be protected from corrosion damage using a preservative. Please consult the manufacturer for a recommendation of a suitable preservative.

## 4 Maintenance/repair

### 4.1 Safety

#### NOTE

Also observe the safety instructions in *Chapter 2 on page 12*.

#### WARNING

##### COMPRESSED AIR IN THE SYSTEM!

There is a risk of injury due to pressurized components and lines.

- ▶ All checks and maintenance tasks must only be performed with the compressor switched off and depressurised.
- ▶ Remove the ignition key from the towing vehicle.

#### CAUTION

##### HOT MACHINE PARTS!

During operation, the compressor is very hot. There is a risk of burning on hot machine parts.

- ▶ Wear protective gloves.

#### NOTICE

##### CLEANING USING A HIGH-PRESSURE JET!

When cleaning a silo vehicle using a high-pressure jet, there is the possibility that water will ingress into the interior of the compressor and the air filter.

- ▶ A distance of 0.5 m must be maintained.
- ▶ If necessary, empty or clean the air filter.
- ▶ In order to prevent corrosion, after cleaning, the compressor must be briefly operated (approx. 10 minutes).

### 4.2 Observe the tightening torques

The tightening torques are specified in the following chapters.

#### WARNING

##### INCORRECT TIGHTENING TORQUE!

An incorrect tightening torque can endanger the secure attachment of the compressor, or result in damage to components due to excessive tightening torque.

- ▶ The specified tightening torques must be observed.

### 4.3 Maintenance Intervals

All of the maintenance and repair tasks given on this page are described in detail in the following *Chapter 4.4 on page 23*.

<b>After the first 2 operating hours</b>	<b>Section</b>
Readjust the tension of the V-belts and quick-release bushings of the V-belt pulleys.	4.4.1
Re-tighten the fastening screws on the discharge silencer.	4.4.2
Perform a visual inspection of the lines to/from the oil cooler and compressor to make sure they do not leak (optional).	3.6
<b>Weekly</b>	
Check the oil level in the compressor and correct as required.	4.4.3
Clean the intake filter or replace if the degree of contamination is excessive and reset the negative pressure maintenance indicator as required.	4.4.4
Check the tension of the V-belts and adjust as necessary.	4.4.1
<b>Quarter-annually</b>	
Carry out a function check of the safety valve.	4.4.5
Carry out a function check of the check valve.	4.4.6
Check the air cooler blades for dirt and clean as needed (IC unit).	4.4.7
<b>Every six months or, if using Silol, once per year</b>	
Carry out an oil change.	4.4.8
Clean the oil intake strainer.	4.4.8

## 4.4 Maintenance work

### 4.4.1 Readjusting the tension of the V-belts and quick-release bushings of the V-belt pulleys

**NOTE**

For the maintenance of the belt drive of a compressor unit based on the CS80 compressor stage (third-party manufacturer), only the instructions from the manufacturer are applicable.

The following applies to the CS700 unit:

**NOTICE**

**ELONGATED V-BELT!**

During the initial 2 operating hours, due to settling, the V-belts elongate and quick-release bushings of the V-belt pulleys lose the correct pretensioning.

- ▶ After the initial 2 operating hours, the V-belts and quick-release bushings of the V-belt pulleys must be retensioned.

- ▶ Loosen the screws (1) and take off the V-belt cover (2).

**Adjusting the tension of the quick-release bushings of the V-belt pulleys**

- ▶ Retighten the V-belt pulley screws (4 and 5).

**Quick-release bushing tightening torques**

Belt pulley nominal diameter	Quick-release bushings	Tightening torque
160 mm	2517	48 Nm
180 mm		
200 mm		
224 mm	3020	90 Nm
250 mm		
280 mm		
315 mm	3525	112 Nm

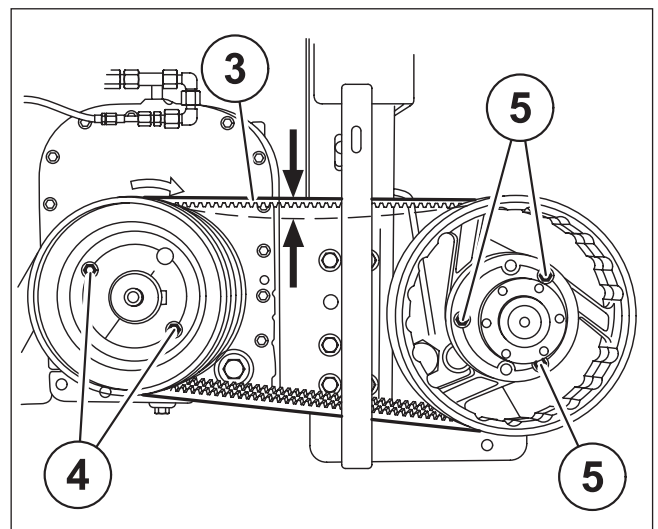
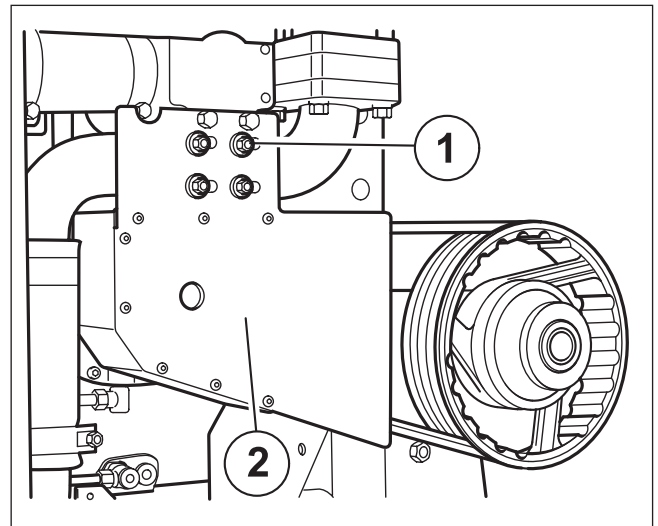

**Checking and setting the tension of the V-belt**

- ▶ Use an appropriate measuring device (e.g. Opti-belt) to check the V-belt tension.
  - ▶ The belt can then be tightened by mechanical measurement or by measurement of the sound waves (belt frequency), according to the selected measuring device.
  - ▶ During the check, follow the operating instructions provided by the manufacturer of the measuring device and adhere to the setpoint values for belt tension listed in the device's operating instructions.
  - ▶ In order to correct the belt tension, loosen the counter nut (6) and retighten the V-belts (3) by turning the adjusting nut (7).
  - ▶ Tighten the lock nut (6).
- Tightening torque (M16 A2-70): 155 Nm**

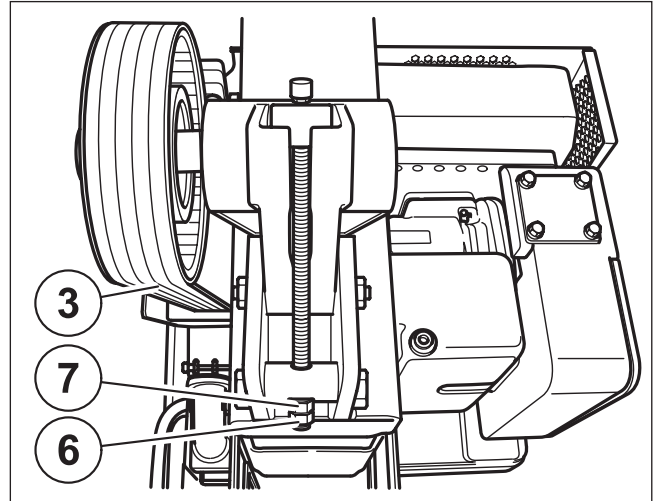
**NOTE**

When tensioning the belt, make sure you follow the operating instructions provided by the manufacturer of the measuring device.

Make sure that the instructions for the SPA/XPA V-belt type are used.

**NOTICE****INCORRECT V-BELT TENSION!**

Excessive V-belt tension can lead to bearing damage and broken shafts. If the V-belt tension is too low, the V-belts can slip during operation and thus wear out prematurely.

- ▶ The V-belt tension must be adjusted according to the manufacturer of the measuring device.

- ▶ Reinstall the V-belt cover.

**Tightening torque (M8 8.8): 25 Nm**

**4.4.2 Retightening the fastening screws on the discharge silencer**

Remove the upper unit covering in order to access the discharge silencer screws.

- ▶ Unscrew the cap nuts (3) from the upper cover.
- ▶ Unscrew the oil dipstick (4).
- ▶ Lift the cover off.

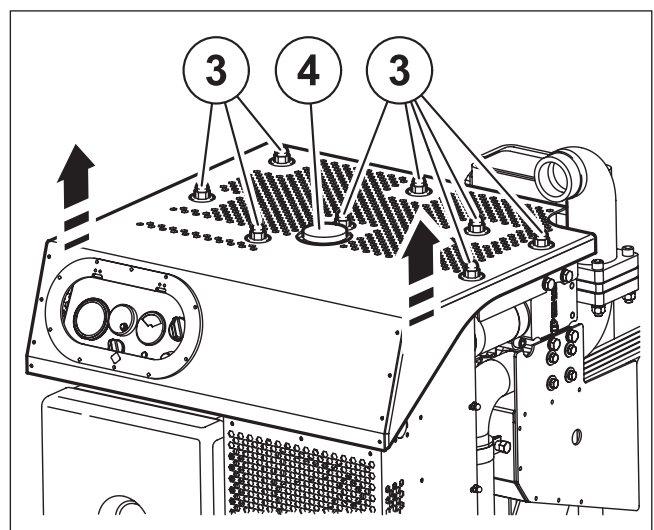



- ▶ Tighten the fastening screws **(2)** on the discharge silencer **(1)**, tightening one screw then tightening the screw opposite.

**Tightening torque (M12 A2-70): 65 Nm**

- ▶ Reinstall the cover and screw in the oil dipstick.

**Tightening torque (M8 A2-70): 18 Nm**

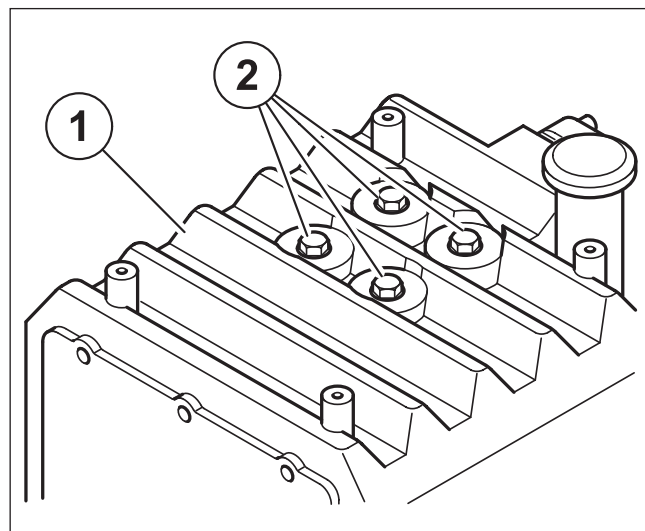

#### 4.4.3 Checking the oil level

- ▶ Unscrew the oil dipstick **(1)** (unit).
- ▶ Unscrew the oil dipstick **(2)** (CS80).
- ▶ Clean the oil dipstick **(1/2)** with a lint-free cloth and screw it back in completely.
- ▶ Unscrew and remove the oil dipstick **(1/2)** again and check the oil level.

#### NOTE

The oil level must be between the marks "min." and "max." on the dipstick. The difference between the markings is approximately 1 litre.

- ▶ Correct the oil level as needed.

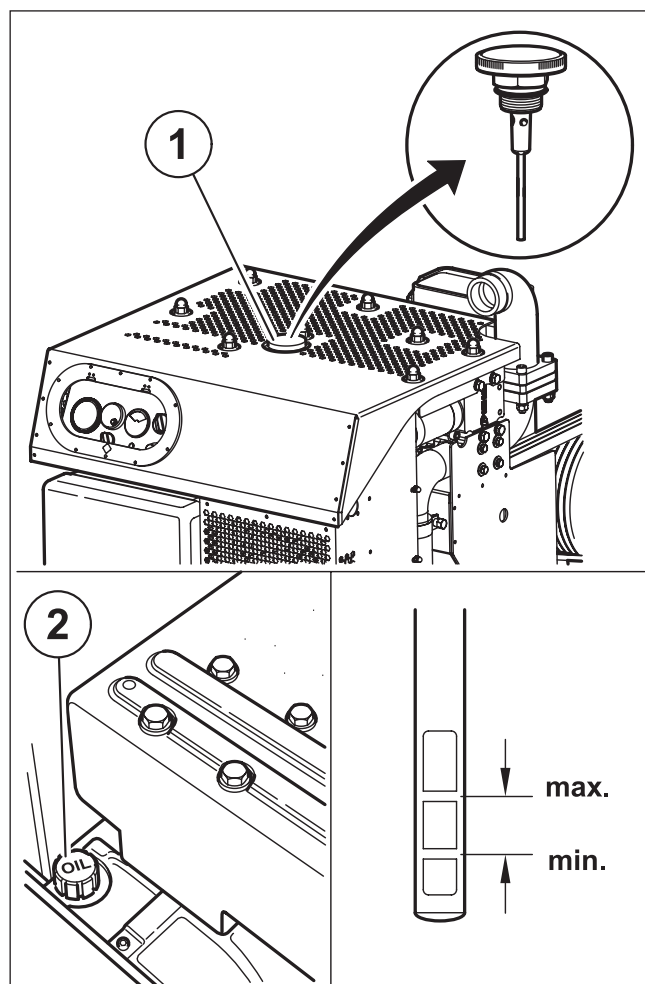

#### 4.4.4 Cleaning and replacing the intake filter element

For the maintenance or replacement of the intake filter of a compressor unit based on the CS80 compressor stage (third-party manufacturer), only the instructions from the manufacturer are applicable.

##### NOTE

Intake filters from diverse manufacturers can be installed. Also observe the instructions from the manufacturer.

- ▶ Loosen the star grip nuts (1) on the compressor unit and then remove the cover (2).
- ▶ Remove filter elements (3).
- ▶ Clean filter elements (3) by lightly tapping or replace if necessary.

##### NOTICE

##### INCORRECT FILTER CLEANING!

Do not clean filter elements with compressed air, benzine or other liquids.

- ▶ Only clean or replace the filter element according to the instructions.

- ▶ Assembly occurs in reverse order.

#### 4.4.5 Check the safety valve

The safety valve is usually installed on the discharge silencer.

##### NOTE

The discharge silencers (1) supplied by GHH RAND have an integrated safety valve (2).

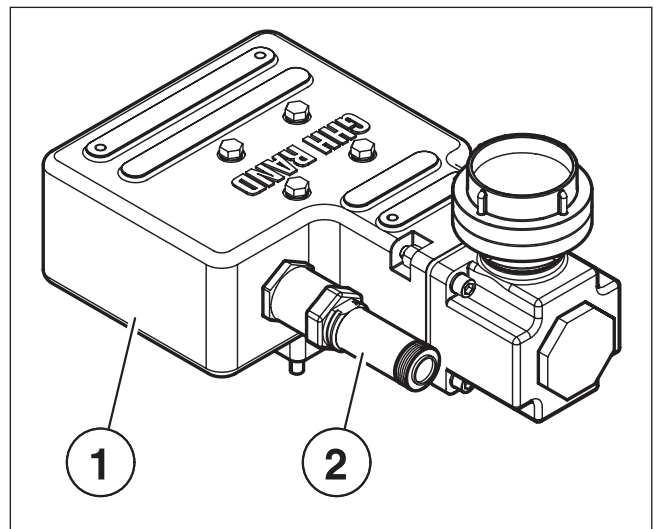
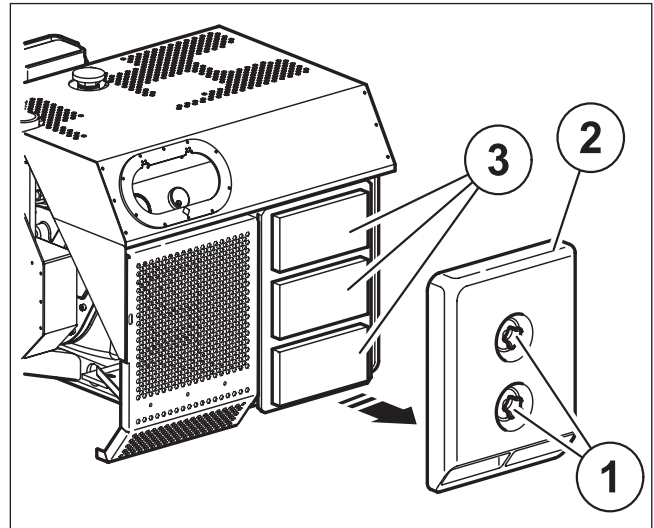

- ▶ In order to check the knurled nut (1), release the safety valve (2). The valve seat (3) must open when released.
- ▶ Tighten the knurled nut (1) on the safety valve (2).
- ▶ Replace safety valve as necessary.

**NOTE**

When installing a new safety valve, heed the manufacturer's instructions.

**WARNING**

**DANGER OF BURSTING!**

No safety valve with a size other than the one provided and/or with a higher response pressure must be used.

- ▶ Only use the safety valves provided.

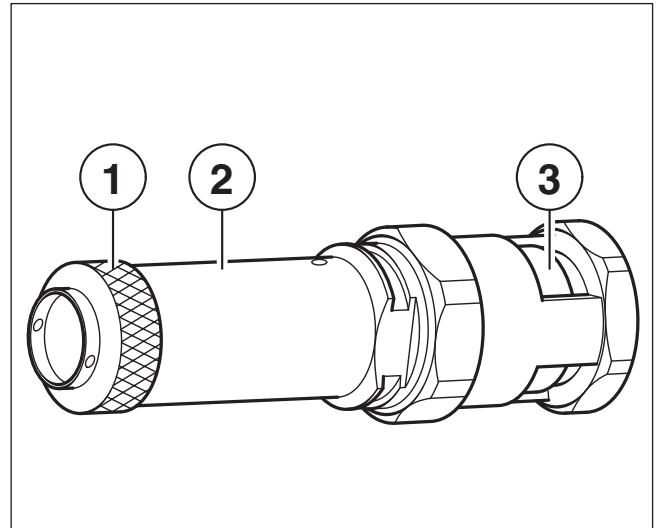

#### 4.4.6 Check the non-return valve

For the maintenance or replacement of the non-return valves of a compressor unit based on the CS80 compressor stage (third-party manufacturer), only the instructions from the manufacturer are applicable.

**NOTE**

Non-return valves from diverse manufacturers can be installed. Also observe the instructions from the manufacturer.

The discharge silencers supplied by GHH RAND have an integrated non-return valve.

- ▶ Remove the cover.
- ▶ Lift off the belt guard.
- ▶ IC unit only:  
open the cooling system and hose band clamp at the discharge head.
- ▶ Remove the pressure joint (2) by releasing the screwed connections (1).
- ▶ Remove the non-return valve (3) and seals (4).
- ▶ Check the movement of the valve disc (5), as necessary, replace the non-return valve (3).
- ▶ Installation is carried out in the reverse sequence. Pay attention to the correct position of the non-return valve.

**Tightening torque (M10 A2-70): 37 Nm**

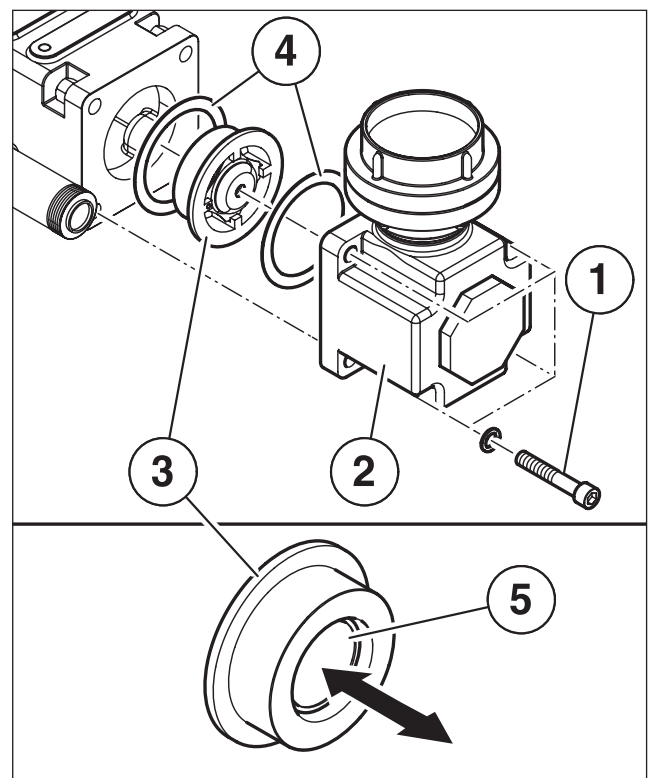

**NOTICE****DAMAGE DUE TO A DEFECTIVE NON-RETURN VALVE!**

Improper assembly can cause damage.

- ▶ When reassembling, always use new seals.
- ▶ Never operate the compressor unit without a non-return valve.

**4.4.7 Testing and cleaning the air cooler****NOTE**

Only with the IC unit.

- ▶ Take off the cover plate (1).
- ▶ Take off the cooling fan housing (2).
- ▶ Blow out cooling fan housing (2) and air cooler (3) with compressed air.
- ▶ After cleaning, mount the cooling fan housing (2) and fit on the cover plate (1).

**Tightening torque (M6 8): 10 Nm**

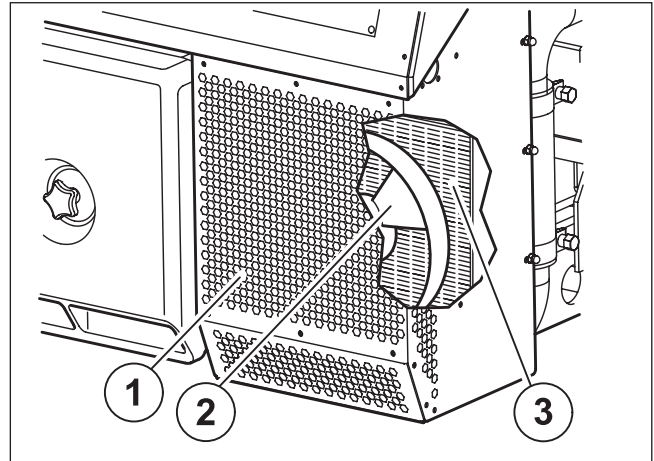
**4.4.8 Oil change and cleaning the oil intake strainer****⚠ CAUTION****ENVIRONMENTAL POLLUTION THROUGH OIL!**

Very small quantities of oil are sufficient to make significant amounts of potable water unusable.

- ▶ During the oil change, make sure that no oil is released into the environment.
- ▶ Dispose of the used oil in accordance with local regulations.

**NOTICE****DAMAGE DUE TO INCORRECT OILS!**

Incorrect oils can destroy the compressor.

- ▶ Only use specified oil (*Chapter 1.9 on page 10*).

**NOTICE****INCORRECT OIL LEVEL!**

If the oil level is insufficient, significant tangible damage can occur. If the oil level is excessive, foaming and, thus, oil leakage can occur.

- ▶ Observe the fill quantity.

- ▶ Unscrew and remove the oil drain plugs **(1 and 4)** from the compressor housing.
- ▶ Collect the oil in a suitable container.
- ▶ Unscrew and clean the oil intake strainer **(3)**.
- ▶ Screw in the oil intake strainer **(3)**.  
**Tightening torque (M20x1.5): 40 Nm**
- ▶ Install the oil drain plugs **(1)** with new seal rings **(2)**.  
**Tightening torque (M30x2): 130 Nm**
- ▶ Install the oil drain plugs **(4)** with new seal rings **(5)**.  
**Tightening torque (M20x1.5): 70 Nm**
- ▶ Fill with oil, fill quantity approx. 9 litres.

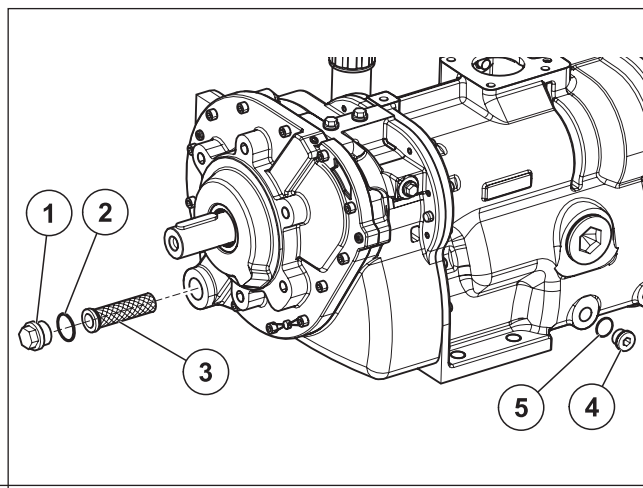

## NOTE

Seal ring **(2)**: DIN 7603 - A30x36 - soft iron.

Seal ring **(5)**: DIN 7603 - A21x26 - soft iron.

## 5 Faults, cause and instructions for troubleshooting

**If in doubt, switch off the compressor!**

<b>Fault</b>	<b>Possible cause</b>	<b>Remedy</b>	<b>Section</b>	
Air quantity not sufficient	Drive speed too low	Increase drive speed to the maximum permitted speed	1.6 - 1.8	
	Suction filter soiled/clogged	Clean or replace filter cartridges or elements as necessary	4.4.4	
Ultimate air pressure too high	Nominal diameter of the compressed air line too small	Install new lines with a larger nominal diameter	-	
	Non-return valve faulty	Check the non-return valve	4.4.6	
	Safety valve does not open	Check the safety valve	4.4.5	
	Drive speed too high	Reduce the drive speed to the maximum permitted speed	1.6 - 1.8	
Ultimate air temperature too high	Intake filter soiled	Clean or replace filter cartridges or elements as necessary	4.4.4	
	Ultimate air pressure too high	Check the safety valve	1.6 - 1.8	
	Ambient temperature too high	Observe permitted intake temperature	1.6 - 1.8	
	Blades of the air cooler dirty (IC unit)	Check air cooler	4.4.7	
	Fan not running (IC unit)		Check control and cable connection	-
			Replace the fuse of the feed line	-
Check the fan selector switch position			3.5.3	
Negative pressure greater than 65 mbar	Intake filter soiled	Clean or replace filter cartridges or elements as necessary	4.4.4	
	Drive speed too high	Reduce the drive speed to the maximum permitted speed	1.6 - 1.8	
Oil pressure less than 0.3 bar	Oil intake strainer soiled	Clean the oil intake strainer	4.4.8	
	Oil level too low	Check oil level and top up as necessary	4.4.3 & 4.4.8	
	Wrong type of oil	Drain oil completely and top up with specified oil	4.4.8	
	Drive speed too low	Increase drive speed to the maximum permitted speed	1.6 - 1.8	
	Bent or damaged oil lines on units with an external oil cooler (optional)	Check oil lines and oil cooler	3.6	

<b>Fault</b>	<b>Possible cause</b>	<b>Remedy</b>	<b>Section</b>
Oil foams	Wrong type of oil	Drain oil completely and top up with specified oil	4.4.8
	Water in the oil		
	Oil quality different		
	Oil level too high	Check oil level and drain off oil as necessary	4.4.3 & 4.4.8
Oil leaks	Oil level too high	Check oil level and drain off oil as necessary	4.4.3 & 4.4.8
	Screw connections leaking	Check screw connections	–
Oil pressure fluctuates	Oil level too low	Check oil level and top up as necessary	4.4.3 & 4.4.8
	Excessive inclination of the compressor	Observe the max. permitted inclination	3.3

Printed in Germany

Reserves the right to amend technical details compared to the information and illustrations of the operating manual. A replication, copying or translation, even in parts, is not permitted without written consent.

As a contribution to environmental protection:  
This paper has been produced from 100% chlorine free bleached pulp.

# GHH RAND®

Service & Support

[www.ingersollrand.com/ghhrandtransport](http://www.ingersollrand.com/ghhrandtransport)



Subject to revision without notice

Printed in Fed. Rep. of Germany

12/2022 EN