



Liftchain Air BOP Handling System

25-75 tons

Articulated trolley allows up to 20 degree side pulling operation

Low maintenance gear motor

Limit switch for upper and lower over-travel protection

Corrosion resistant load chain.

Ergonomic pendant with optional emergency stop/start feature

Corrosion Resistant marine grade paint

Automatic Fail-Safe, multi disc, motor brake on hoist

Rugged All Steel Construction delivers long-life and durability

Bottom block mounted on bearing with external lubrication point and water drain

Available with bottom hook or clevis

Ideal for:



Onshore



Offshore



Liftchain Air BOP Handling System

25-75 tons

Ingersoll Rand's Liftchain BOP (Blowout Preventer) Handling Systems are driven by reliable air motors that are virtually maintenance free. With an all-steel construction they are available in low and ultra-low headroom models to handle your BOP stack with ease.



General Characteristics

Model	Lifting Capacity Metric Tons	Reeves of Chain	Standard Lift m (ft)	Standard Control Length m (ft)	Headroom mm (in)	Trolley Flange Adjustment Range mm (in)	Standard System Weight kg (lb)	Weight per Additional Meter of Lift kg (lb)	Wheel Loading per Pair kg (lb)
BS25	25 (12.5x2)	2	9 (30)	9 (30)	995 (39.2)	130-310 (5-12)	807 (1,775)	23 (50)	6,250 (13,750)
BS30	30 (15x2)	3	9 (30)	9 (30)	1195 (47.0)	140-310 (5.5-12)	1,543 (3,395)	34 (75)	7,500 (16,500)
BS36	36 (18x2)	3	9 (30)	9 (30)	1195 (47.0)	140-310 (5.5-12)	1,543 (3,395)	34 (75)	9,000 (19,800)
BS40	40 (20x2)	4	9 (30)	9 (30)	1240 (48.8)	140-310 (5.5-12)	1,710 (3,762)	46 (101)	12,500 (27,500)
BS50Q	50 (25x2)	4	9 (30)	9 (30)	1240 (48.8)	140-310 (5.5-12)	1,710 (3,762)	46 (101)	12,500 (27,500)
BS50	50 (25x2)	2	9 (30)	9 (30)	990 (39.0)	140-310 (5.5-12)	1,942 (4,272)	42 (92)	6,250 (13,750)
BS75	75 (37.5x2)	3	9 (30)	9 (30)	1134 (44.6)	160-310 (6-12)	3,684 (8,105)	64 (141)	9,375 (20,625)

Performance

Model	Hoist Performance							Trolley Performance				
	Lifting Capacity Metric Tons	Lifting Speed			Lowering speed m/min (fpm)	Air inlet	Required Air Flow m ³ /min (cfm)	Working Air Pressure bar (psi)	Powered Trolley Traverse Speed ⁽¹⁾ m/min (fpm)	Required Air Flow m ³ /min (cfm)	Working Air Pressure bar (psi)	Sound Level dB(A)
		Full Load m/min (fpm)	No Load m/min (fpm)	Full Load m/min (fpm)								
BS25	25 (12.5x2)	1.1 (3.6)	1.8 (.9)	1.3 (4.3)	3/4 BSP	5 (176)	6.3 (90)	12 (39)	1.9 (67)	6.3 (90)	79	
BS30	30 (15x2)	0.8 (2.6)	1.2 (3.9)	0.9 (3.0)	3/4 BSP	5 (176)	6.3 (90)	12 (39)	1.9 (67)	6.3 (90)	79	
BS36	36 (18x2)	0.7 (2.3)	1.2 (3.9)	0.9 (6.2)	3/4 BSP	5 (176)	6.3 (90)	12 (39)	1.9 (67)	6.3 (90)	79	
BS40	40 (20x2)	0.4 (1.3)	0.8 (2.6)	0.6 (2.0)	3/4 BSP	5 (176)	6.3 (90)	12 (39)	1.9 (67)	6.3 (90)	79	
BS50Q	50 (25x2)	0.5 (1.6)	0.9 (6.2)	0.6 (2.0)	3/4 BSP	5 (176)	6.3 (90)	12 (39)	1.9 (67)	6.3 (90)	79	
BS50	50 (25x2)	1.5 (4.9)	3.0 (9.8)	2.5 (8.2)	1-1/4 BSP	12 (423)	6.3 (90)	12 (39)	1.9 (67)	6.3 (90)	79	
BS75	75 (37.5x2)	1.0 (3.3)	2.0 (6.6)	1.7 (5.6)	1-1/4 BSP	12 (423)	6.3 (90)	12 (39)	3.8 (134)	6.3 (90)	79	

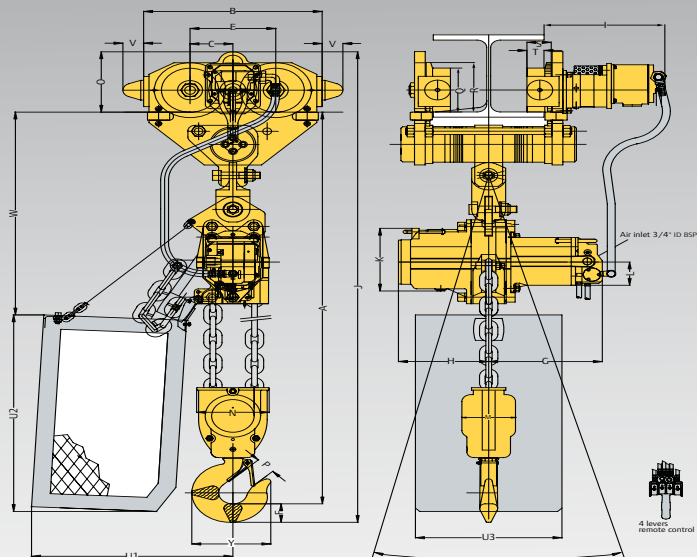

Vertical Angle	10	20
Reduced Working Capacity	2%	6%

Chain Container Dimensions for 9m (30 ft) standard lift ⁽¹⁾

Model	U1 mm (in)	U2 mm (in)	U3 mm (in)
BS25	565 (22.24)	720 (28.35)	400 (15.75)
BS30	565 (22.24)	720 (28.35)	400 (15.75)
BS36	565 (22.24)	720 (28.35)	400 (15.75)
BS40	565 (22.24)	720 (28.35)	550 (21.65)

⁽¹⁾ Chain containers are available with many other dimensions. Please contact Client Services for details.

Model	A	B	C	E	F	G	H	I	J	K
BS25	1,128 (44.41)	616 (24.24)	120 (4.72)	240 (9.45)	67 (2.64)	318 (12.52)	253 (9.96)	338 (13.3)	1,415 (55.7)	228 (8.98)
BS30	1,242 (48.9)	758 (29.83)	156 (6.14)	312 (12.28)	80 (3.15)	377 (14.84)	311 (12.24)	342 (13.46)	1,592 (62.68)	228 (8.98)
BS36	1,242 (48.9)	758 (29.83)	156 (6.14)	312 (12.28)	80 (3.15)	377 (14.84)	311 (12.24)	342 (13.46)	1,592 (62.68)	228 (8.98)
BS40	1,290 (50.79)	758 (29.83)	156 (6.14)	312 (12.28)	94 (3.7)	377 (14.84)	311 (12.24)	342 (13.46)	1,592 (62.68)	228 (8.98)
BS50Q	1,290 (50.79)	642 (25.27)	156 (6.14)	312 (12.28)	94 (3.7)	377 (14.84)	311 (12.24)	342 (13.46)	1,606 (63.23)	228 (8.98)

Model	M	N	O	P	Q	R	S	T	W	Y
BS25	150 (5.9)	203 (7.99)	220 (8.66)	58 (2.28)	160 (6.3)	200 (7.87)	48 (1.89)	68 (2.68)	739 (29.09)	222 (8.74)
BS30	200 (7.87)	206 (8.11)	270 (10.63)	78 (3.07)	225 (8.86)	272 (10.71)	56 (2.2)	80 (3.15)	797 (31.38)	283 (11.14)
BS36	200 (7.87)	206 (8.11)	270 (10.63)	78 (3.07)	225 (8.86)	272 (10.71)	56 (2.2)	80 (3.15)	797 (31.38)	283 (11.14)
BS40	200 (7.87)	235 (9.25)	270 (10.63)	87 (3.42)	225 (8.86)	272 (10.71)	56 (2.2)	80 (3.15)	797 (31.38)	339 (13.35)
BS50Q	200 (7.87)	235 (9.25)	270 (10.63)	87 (3.42)	225 (8.86)	272 (10.71)	56 (2.2)	80 (3.15)	58 (2.28)	797 (31.38)

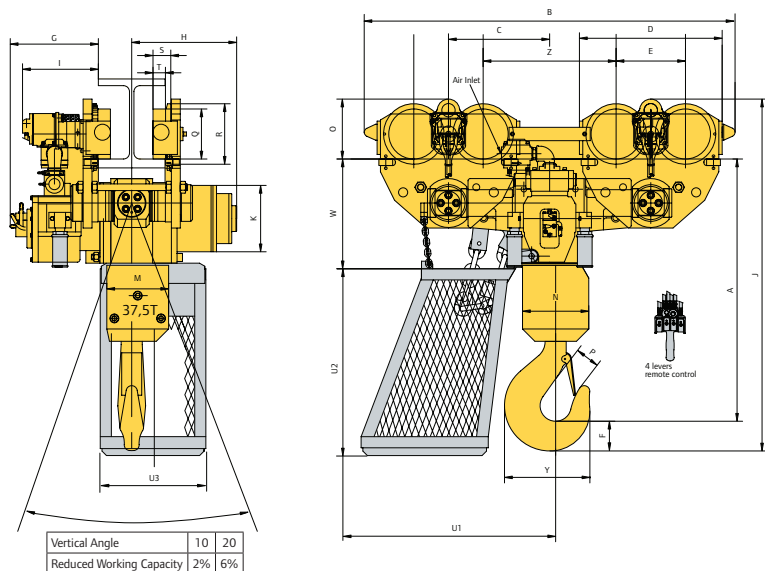

Vertical Angle	10	20
Reduced Working Capacity	2%	6%

Chain Container Dimensions for 9m (30 ft) standard lift ⁽¹⁾

Model	U1 mm (in)	U2 mm (in)	U3 mm (in)
BS50Q	565 (22.24)	720 (28.35)	550 (21.65)
BS50	795 (31.3)	706 (27.8)	533 (21.0)
BS75	886 (34.9)	859 (33.8)	610 (24.0)
BS100	922 (36.3)	935 (36.8)	635 (25.0)

⁽¹⁾ Chain containers are available with many other dimensions. Please contact Client Services for details.

Model	A	B	C	D	E	F	G	H	I	J	K	L
BS50	976 (38.42)	1,240 (48.82)	370 (14.57)	500 (19.68)	240 (9.45)	97 (3.82)	492 (19.37)	367 (14.45)	342 (13.46)	1,293 (50.9)	223 (8.78)	196 (7.72)
BS75	1,170 (46.06)	1,552 (61.1)	455 (17.91)	642 (25.28)	312 (12.28)	132 (5.2)	547 (21.5)	472 (18.58)	360 (14.17)	1,572 (61.89)	223 (8.78)	196 (7.72)

Model	M	N	O	P	Q	R	S	T	V	W	Y	Z
BS50	190 (7.48)	276 (10.87)	220 (8.66)	82 (3.23)	160 (6.3)	200 (7.87)	48 (1.89)	68 (2.68)	58 (2.28)	58 (17.16)	384 (13.35)	500 (19.68)
BS75	278 (10.94)	298 (11.73)	270 (10.63)	103 (4.05)	225 (8.86)	272 (10.71)	56 (2.2)	80 (3.15)	58 (2.28)	58 (19.45)	384 (15.12)	598 (23.54)

Dimensions mm (in)

How to Order

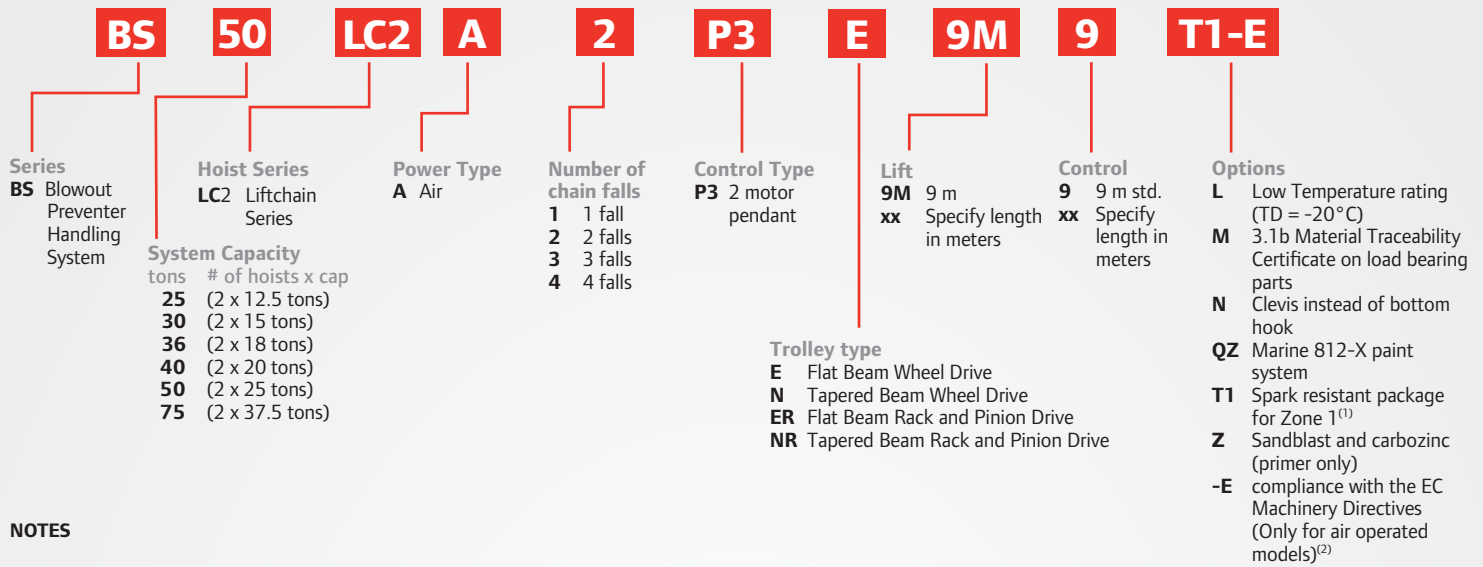

NOTES

⁽¹⁾ **Spark resistant option T1 includes:**

For the hoist:

- Stainless steel pins and fasteners 10 mm and smaller
- 20µ zinc plated fasteners 11 mm and larger
- Cast iron pendant (air only)
- Bronze coated bottom hook assembly

For the trolley:

- Stainless steel pins and fasteners 10 mm and smaller
- 20µ zinc plated fasteners 11 mm and larger
- Solid bronze wheels
- Cast iron pendant (air only)

⁽²⁾ **EC Machinery Directives include:**

- Overload protection
- Emergency stop button
- Main air shut off valve
- CE declaration of conformity



For More Information www.ingersollrandproducts.com/lifting lifting@irco.com

Ingersoll Rand, IR, the IR logo and Impactool are trademarks of Ingersoll Rand, its subsidiaries and/or affiliates. All other trademarks are the property of their respective owners. Nothing contained on these pages is intended to extend any warranty or representation, expressed or implied, regarding the product described herein. Any such warranties or other terms and conditions of sale of products shall be in accordance with Ingersoll Rand's standard terms and conditions of sale for such products, which are available upon request. Product improvement is a continuing goal at Ingersoll Rand. Designs and specifications are subject to change without notice or obligation. Unless otherwise noted this equipment is not designed for transporting people or lifting loads over people. It is the user's responsibility to determine the suitability of this product for any particular use and to check compliance with applicable regulations. Before installation, see maintenance and operations manual for additional warnings and precautions.