

Mounting instructions

(Translation of the original instructions)

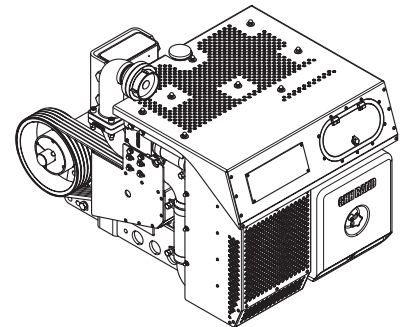
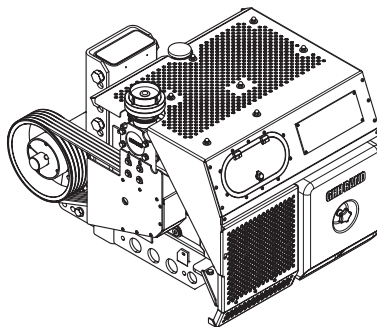
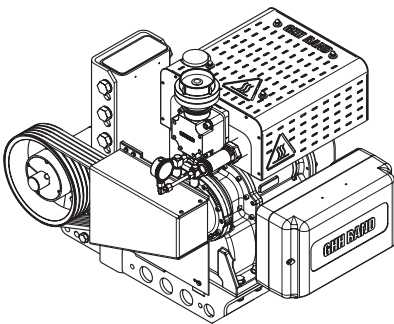
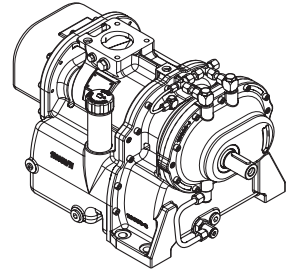

SILU CG80
SILU CG600 LITE
SILU CG600 STANDARD
SILU CG600 IC

DE WICHTIG!

Die Betriebsanleitung liegt in Ihrer Landessprache zusammen mit der Montageanleitung (englische und deutsche Ausführung) elektronisch auf der Webseite www.ingersoll.com/ghhrandtransport für den Download bereit. Auf Anfrage senden wir Ihnen auch gerne eine gedruckte Version zu.

EN IMPORTANT!

The operating instructions can be downloaded electronically in your language, together with the mounting instructions (in English and German) from the website www.ingersollrand.com/ghhrandtransport. On request, we will gladly send you a printed version.

CZ DŮLEŽITÉ!

Návod k provozu je k dispozici ke stažení v jazyce Vaší dané země společně s návodem pro montáž (anglická nebo německá verze) elektronicky na webové stránce www.ingersollrand.com/ghhrandtransport. Na vyžádání vám rádi zašleme i tištěnou verzi.

FR IMPORTANT !

Vous pouvez télécharger la manuel d'utilisation dans la langue de votre pays avec les instructions de montage (en anglais et en allemand) au format électronique sur le site Web www.ingersollrand.com/ghhrandtransport. Sur demande, nous vous enverrons volontiers une version imprimée.

NL BELANGRIJK!

De gebruikshandleiding kan samen met de montagehandleiding (Engelse en Duitse versie) in uw taal elektronisch worden gedownload van de website www.ingersollrand.com/ghhrandtransport. Op aanvraag sturen we u met alle plezier ook een gedrukte versie.

PL WAŻNE!

Instrukcja obsługi dostępna jest w ojczystym języku użytkownika wraz z instrukcją montażu (w języku angielskim i niemieckim) w elektronicznej formie do pobrania na stronie internetowej www.ingersollrand.com/ghhrandtransport. Na życzenie chętnie prześlemy Państwu również wersję drukowaną.

PT IMPORTANTE!

O manual de instruções está pronto para ser descarregado na sua língua-mãe, juntamente com o manual de montagem (versão em inglês e alemão), em formato eletrónico na página web www.ingersollrand.com/ghhrandtransport. A pedido, podemos também fornecer-lhe uma versão impressa.

RO IMPORTANT!

Instrucțiunile de exploatare în limba țării dvs., împreună cu instrucțiunile de montaj (versiunea în limba engleză și germană) sunt disponibile pentru descărcare în format electronic pe site-ul web www.ingersollrand.com/ghhrandtransport. De asemenea, la cerere vă putem trimite o versiune tipărită.

HU FONTOS!

Az üzemeltetési útmutató az Ön nyelvén a szerelési útmutatóval (angol és német nyelvű változat) együtt elektronikusan letölthető a www.ingersollrand.com/ghhrandtransport webhelyről. Kérésére szívesen küldünk egy kinyomtatott változatot is.

BY ВАЖНА!

Электронную версію кіраўніцтва па эксплуатацыі на нацыянальнай мове разам з інструкцыяй па мантажы (на англійскай і нямецкай мовах) можна спампаваць на сайце www.ingersollrand.com/ghhrandtransport. Па асобным запыце мы з задавальненнем дашлем вам друкаваную версію.

SI POMEMBNO!

Navodila za uporabo so v elektronski obliki na voljo za prenos v vašem lokalnem jeziku skupaj z navodili za montažo (angleška in nemška različica) na spletni strani www.ingersollrand.com/ghhrandtransport. Na zahtevo vam bomo z veseljem poslali tudi tiskano različico.

LT SVARBU!

Elektroninę eksploataavimo instrukcijos Jūsų šalies kalba versiją kartu su montavimo instrukcija (anglų ir vokiečių kalbomis) galite atsisiųsti iš interneto svetainės www.ingersollrand.com/ghhrandtransport. Jei pateiksite užklausą, mielai atsiųsime ir išspausdintą versiją.

Introduction

Before installing and commissioning the SILU CG80 screw compressor or the SILU CG600 LITE, SILU CG600 STANDARD, SILU CG600 IC compressor units, please read through these mounting instructions carefully (the additional designation SILU is not used in the rest of these mounting instructions).

The mounting instructions describe how to erect and commission the above-mentioned compressors. Make sure that these mounting instructions are available to the installation personnel and that the tasks are carried out in accordance with the instructions contained in it.

Scope of application of the mounting instructions

The mounting instructions only contain instructions for mounting the above-mentioned screw compressor and the above-mentioned screw compressor units. The mounting instructions do not apply for the installation of components/units from other companies by an external installer. If a third-party manufacturer designs and manufactures a compressor unit based on the CG80 compressor stage, they are obliged to provide the end user with their own operating instructions.

Target group

The mounting instructions are restricted exclusively for use by qualified specialists.

Notes and safety instructions

The following instructions and safety notices are used in the mounting instructions to warn of dangers which could result in operating errors, injuries and tangible damage:

DANGER

DANGER warns of an imminent danger and indicates an imminent danger. This safety note warns of possible irreversible to fatal injuries.

WARNING

WARNING indicates a possible imminent danger. This safety note warns of serious or perilous injuries.

CAUTION

CAUTION indicates a possible imminent danger. This safety note warns of light injuries.

NOTICE

ATTENTION warns of possible tangible damage or malfunctions.

NOTE

NOTES contain instructions to prevent operating errors and other specific useful or important information.

Contents

1	GENERAL	7
1.1	Application	7
1.2	Manufacturer's address	7
1.3	Screw compressor type plate	7
1.4	Compressor unit type plate.....	8
1.5	Information for enquiries and orders	8
1.6	Service & Support	8
1.7	Technical data CG80 screw compressor	9
1.7.1	Performance data CG80 screw compressor	11
1.8	Technical data CG600 LITE compressor unit.....	13
1.9	Technical data CG600 compressor unit.....	14
1.10	Technical data CG600 IC compressor unit.....	15
1.11	Technical data compressor unit.....	16
1.12	Operating the compressor at high altitudes.....	17
1.13	Maximum running time	17
1.14	External oil cooler for extreme conditions.....	18
2	SAFETY	19
2.1	General.....	19
2.2	Authorised personnel, training and qualification.....	19
2.3	Safety-conscious work.....	19
2.4	Safety instructions for the owner/operator	19
2.5	Unauthorised conversions and spare parts.....	20
2.6	Incorrect operating methods.....	20
2.7	Disposal.....	20
3	INSTALLATION GUIDELINES	21
3.1	Internal transportation	21
3.1.1	Internal transportation of the screw compressor	21
3.1.2	Internal transportation of the unit	22
3.2	Drive	22
3.2.1	V-belt drive.....	22
3.2.2	Articulated shaft	23
3.2.3	Direct drive.....	23
3.3	Installation and position	23
3.3.1	Permitted inclination.....	24
3.4	Preparing installation.....	24
3.4.1	Required space conditions for the unit	24
3.4.2	Checking the direction of rotation.....	24
3.4.3	Checking the direction of rotation of the unit	24
3.4.4	Aligning the compressor unit on the vehicle/flange parallelism.....	24
3.4.5	Air flow CG600 IC	25
3.5	Observe the tightening torques	25
3.6	Completion of the screw compressor.....	26
3.6.1	Installing the hose connection flange (example)	26
3.6.2	Installing the maintenance indicator on the hose connecting flange	26
3.6.3	Installing the oil pressure gauge.....	27
3.6.4	Oil cooler connection on the compressor (optional).....	27

3.6.5	Installing the intake silencer and air filter	28
3.6.6	Mounting the discharge silencer	28
3.6.7	Installing the safety valve	29
3.6.8	Installing the non-return valve	30
3.6.9	Installing the oil dipstick	31
3.6.10	Installing the screw compressor on the mounting console (third-party manufacturer)	31
3.6.11	Installing the pressure line	31
3.7	Completion of the compressor unit.....	32
3.7.1	Test mounting of the compressor unit.....	32
3.7.2	Installing the compressor unit.....	34
3.7.3	Installing the articulated shaft.....	35
3.8	Connecting the external oil cooler (optional)	37
3.8.1	Installing the external oil cooler fan controller (optional)	37
3.9	Connecting the control unit CG600 IC	38
4	SAFETY LABELS	39
4.1	Attaching the stickers to the unit (example).....	40
5	INITIAL COMMISSIONING	41
5.1	Lubricant	41
5.2	Filling with lubricant.....	42
5.3	Removing the preservation.....	42
5.4	Test run.....	43
5.4.1	Switching on	43
5.4.2	Checking the direction of rotation.....	43
5.4.3	Checking the drive speed.....	44
5.4.4	Cooling fan CG600 IC.....	44
5.4.5	Function control of external oil cooler fan (optional).....	44
5.4.6	Switching off	44
5.4.7	Checks after the test run	45

1 General

1.1 Application

GHH RAND builds and supplies the CG80 screw compressor and the CG600 compressor units for installation on silo vehicles for the connection-ready unit.

Because of their oil-free compression of atmospheric air and their power-to-weight ratio for installation on silo vehicles, the compressor unit is used to pneumatically convey bulk goods, such as flour, sugar, salt, animal feed, powdered chemicals, dry granulate, soda, cement, sand, lime, plaster, etc.

The products built and supplied by GHH RAND are only designed for the operation at and on utility vehicles that exclusively drive on paved roads.

A different use requires consultation with the manufacturer.

1.2 Manufacturer's address

GHH RAND
Schraubenkompressoren GmbH
Max-Planck-Ring 27
46049 Oberhausen

1.3 Screw compressor type plate

The type plate is attached to the side of the screw compressor. It contains the following information:

- Type
- Serial no.
- Rotational speed range
- max. volume flow
- At max. operating pressure
- max. power consumption

NOTE

The complete identification has certificate value and may not be changed or rendered illegible.

1.4 Compressor unit type plate

The type plate on the compressor unit is attached to the mounting console.

It contains the following information:

- Type
- Year of Manufacture
- Compressor serial no.
- Unit serial no.
- V-belt drive ratio
- Unit drive speed
- Intake volume
- max. operating pressure

NOTE

The complete identification has certificate value and may not be changed or rendered illegible.

1.5 Information for enquiries and orders

If you have enquiries or orders for spare parts and accessories, please provide details of the exact type designation and the serial number of the screw compressor or the compressor unit, for which the spare part or accessory is intended.

CAUTION

USE OF UNAUTHORISED SPARE PARTS AND ACCESSORIES!

Original replacement parts and accessories that are authorised by the manufacturer represent safety factors. The use of non-original or non-authorised replacement parts and accessories may void the liability for the resulting consequences.

- ▶ Only use original spare parts and accessories authorised and approved by the manufacturer.

1.6 Service & Support

www.ingersollrand.com/ghhrandtransport

Dimensions & weight			Rotational speed range	
Length (approx)	mm	614	min. rpm	3000
Width (approx.)	mm	389	max. rpm	3600
Height (approx)	mm	365		
Weight (approx)	kg	106		
Maximum operating pressure			Oil filling quantity	
max. 2.5 bar			approx. 9 litres	
Maximum intake negative pressure			Minimum oil pressure	
max. 65 mbar			min. 0.3 bar	
Connection dimensions				
Thread of attachment screw		4 x M16		
Intake flange		NW80/Ø122 - 4 x M12		
Pressure flange		NW65/Ø118 - 4 x M12		
Drive journal		Ø 35 m6/60 lg Permitted radial force $F_{r_{max.}} = 5000 \text{ N}$ (measured 35 mm from shaft shoulder)		
Feather key		A10 x 8 x 50 DIN 6885		
Compressor direction of rotation		Clockwise (viewed looking towards the drive journal)		

NOTE

More detailed information can be found in the separately available installation drawing of the screw compressor.

1.7.1 Performance data CG80 screw compressor

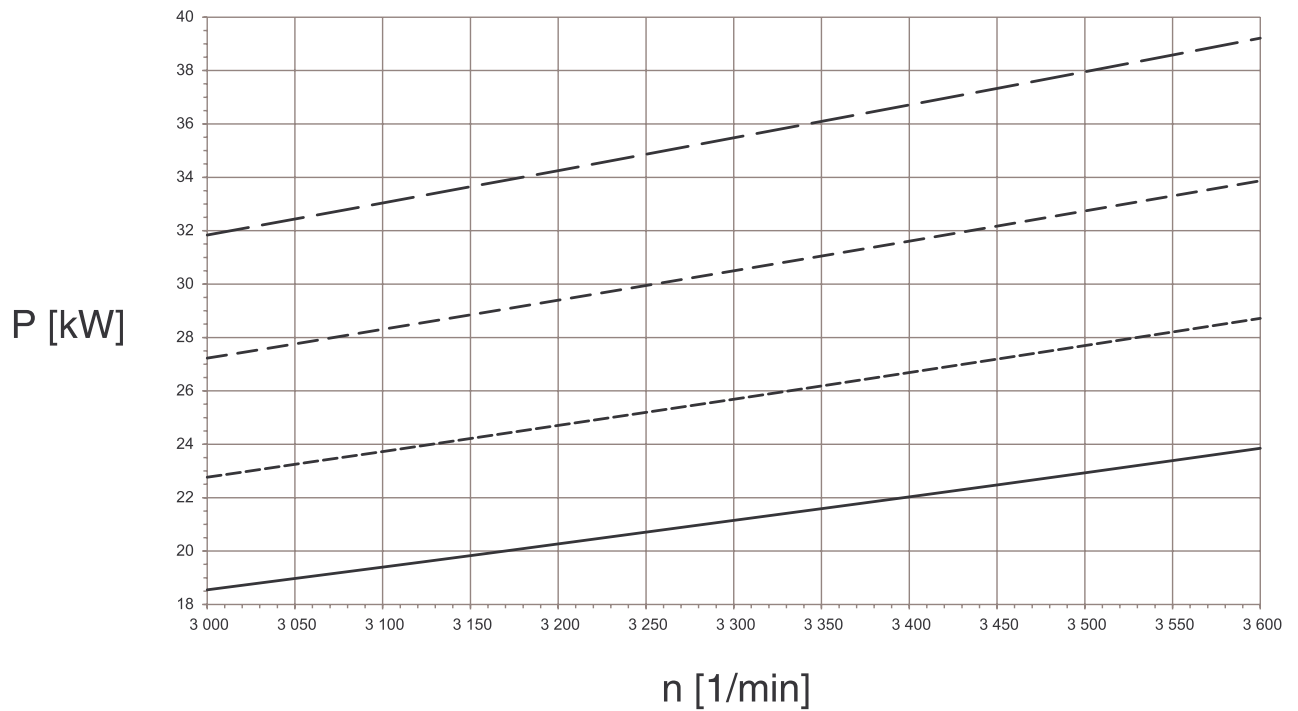
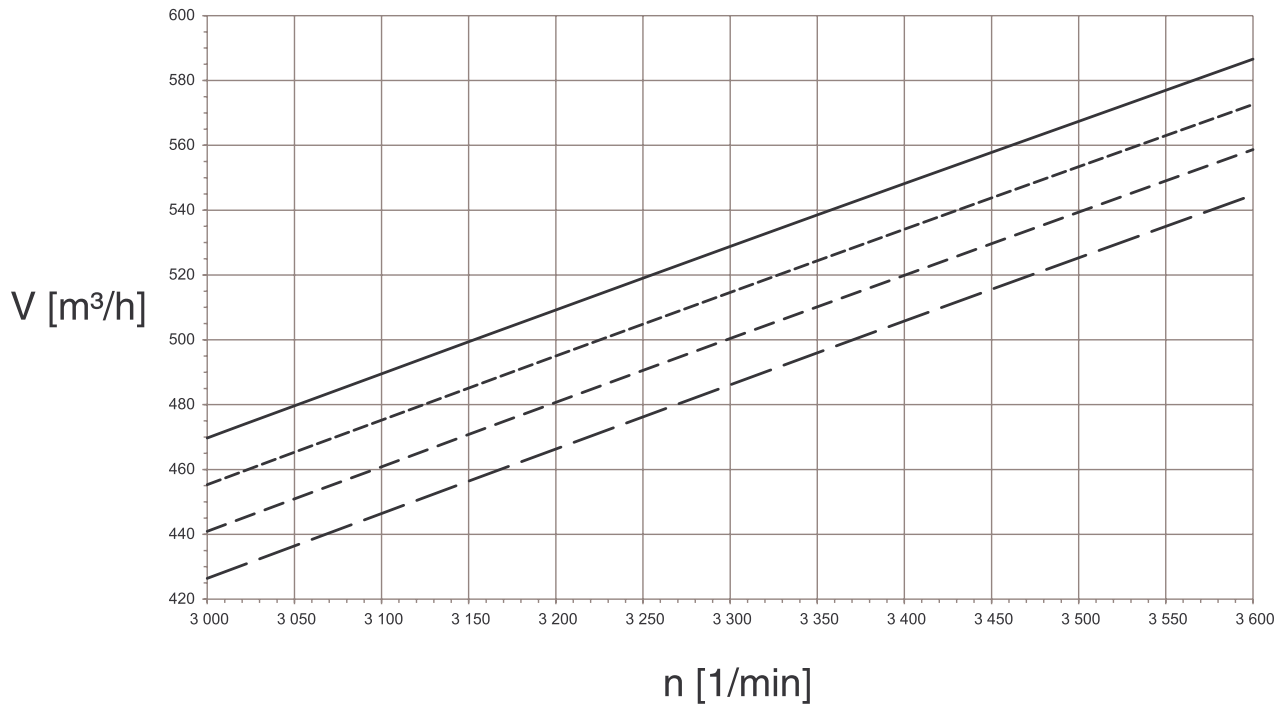

All information for:

Feed medium: atmospheric air
 Intake pressure: 1 bar (abs.)
 Intake temperature: 20 °C
 Permitted min. ambient temp.: -20 °C
 Relative humidity: 60 %
 Technical data without intake or pressure losses

n Drive speed
 V Intake volume
 t_2 Final temperature
 P Coupling output
 $t_{1,\text{max}}$ Permitted intake temperature

Pressure difference:

— 1.0 bar
 - - - 1.5 bar
 - · - · 2.0 bar
 - - - - 2.5 bar
 ····· ≤ 2.0 bar

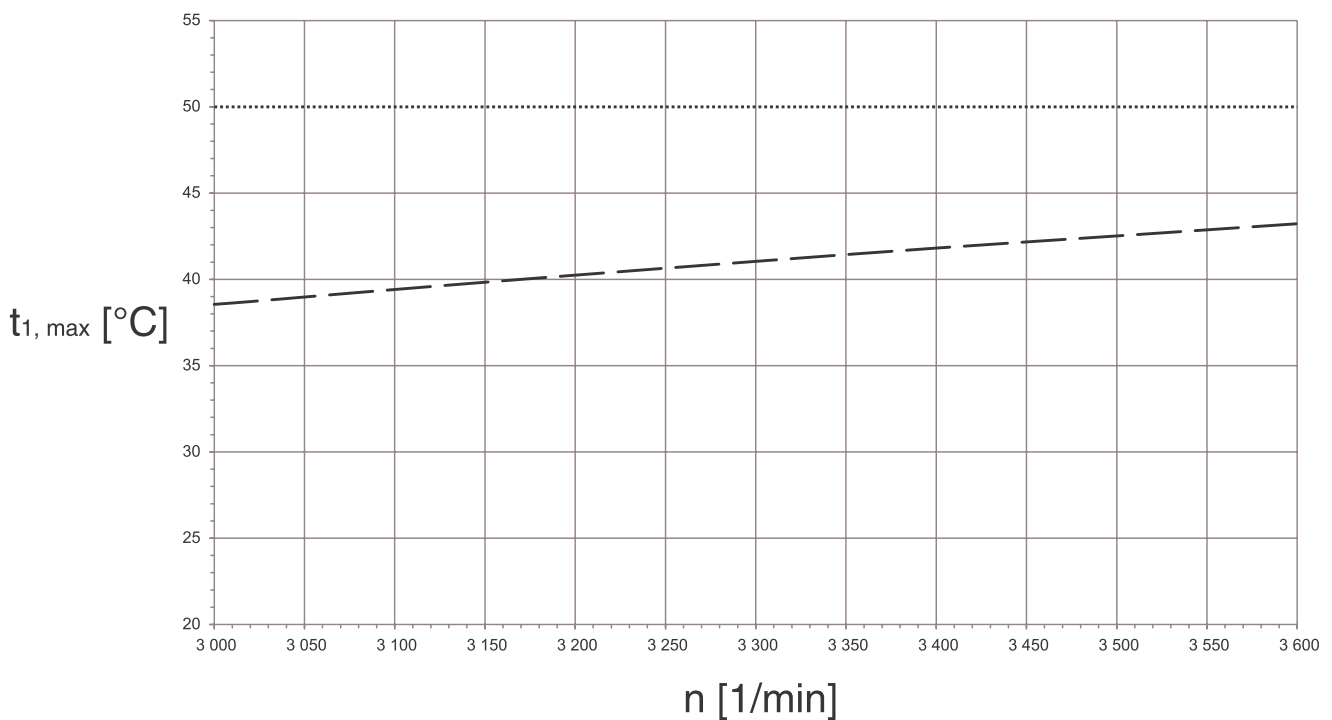
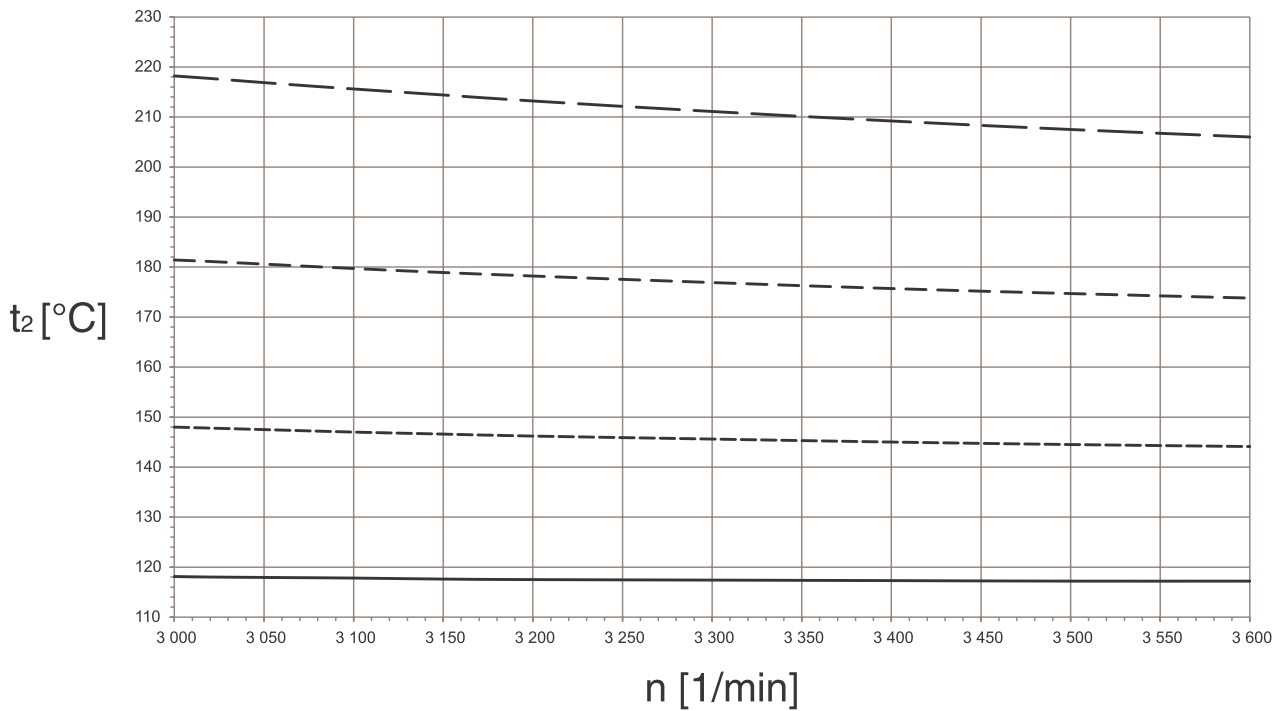

All information for:

Feed medium: atmospheric air
 Intake pressure: 1 bar (abs.)
 Intake temperature: 20 °C
 Permitted min. ambient temp.: -20 °C
 Relative humidity: 60 %
 Technical data without intake or pressure losses

n Drive speed
 V Intake volume
 t_2 Final temperature
 P Coupling output
 $t_{1,max}$ Permitted intake temperature

Pressure difference:

———— 1.0 bar
 - - - - - 1.5 bar
 - - - - - 2.0 bar
 - - - - - 2.5 bar
 ≤ 2.0 bar

1.8 Technical data CG600 LITE compressor unit

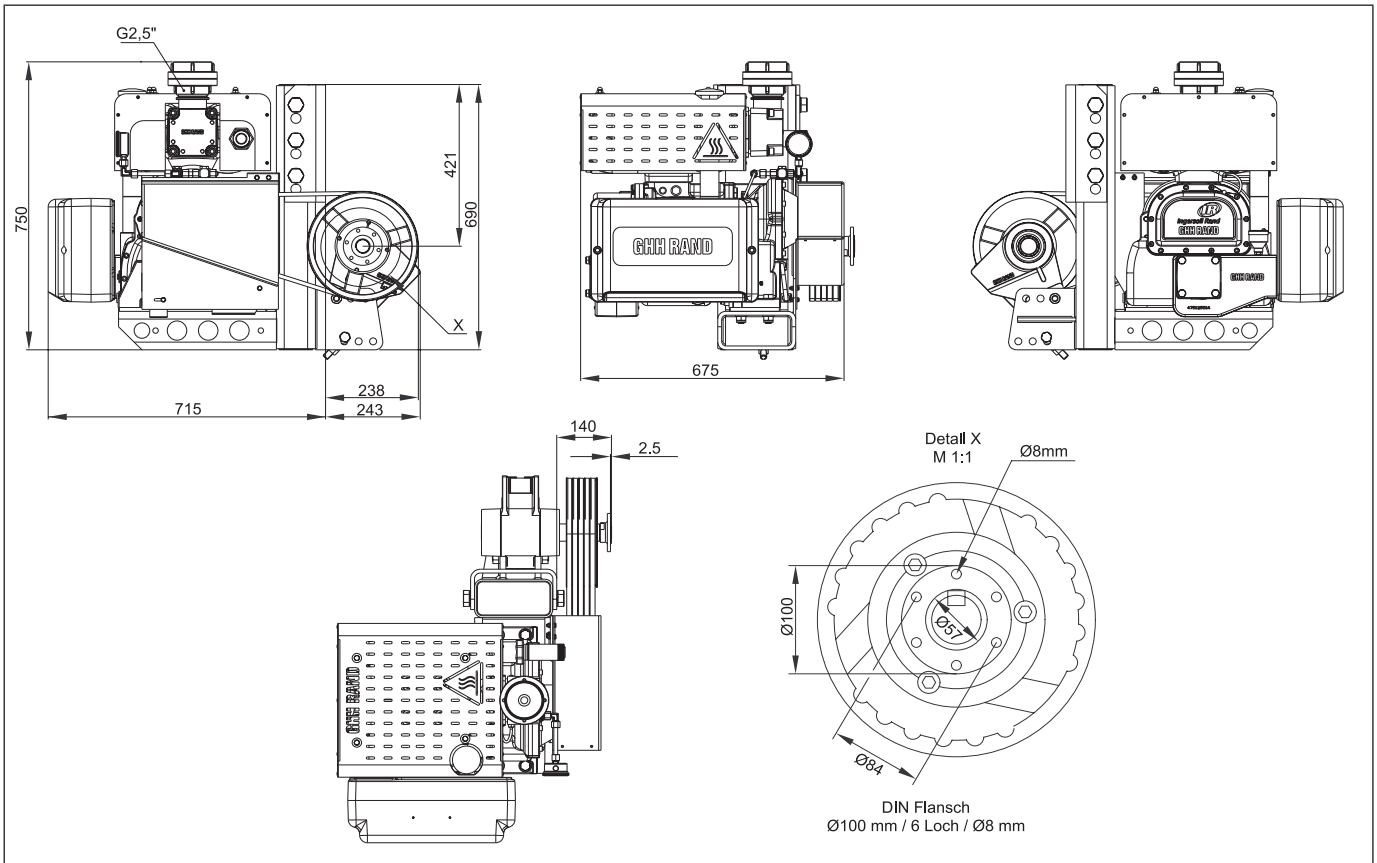

Model: R - PTO L (standard ratio)

All dimensions are approximate.

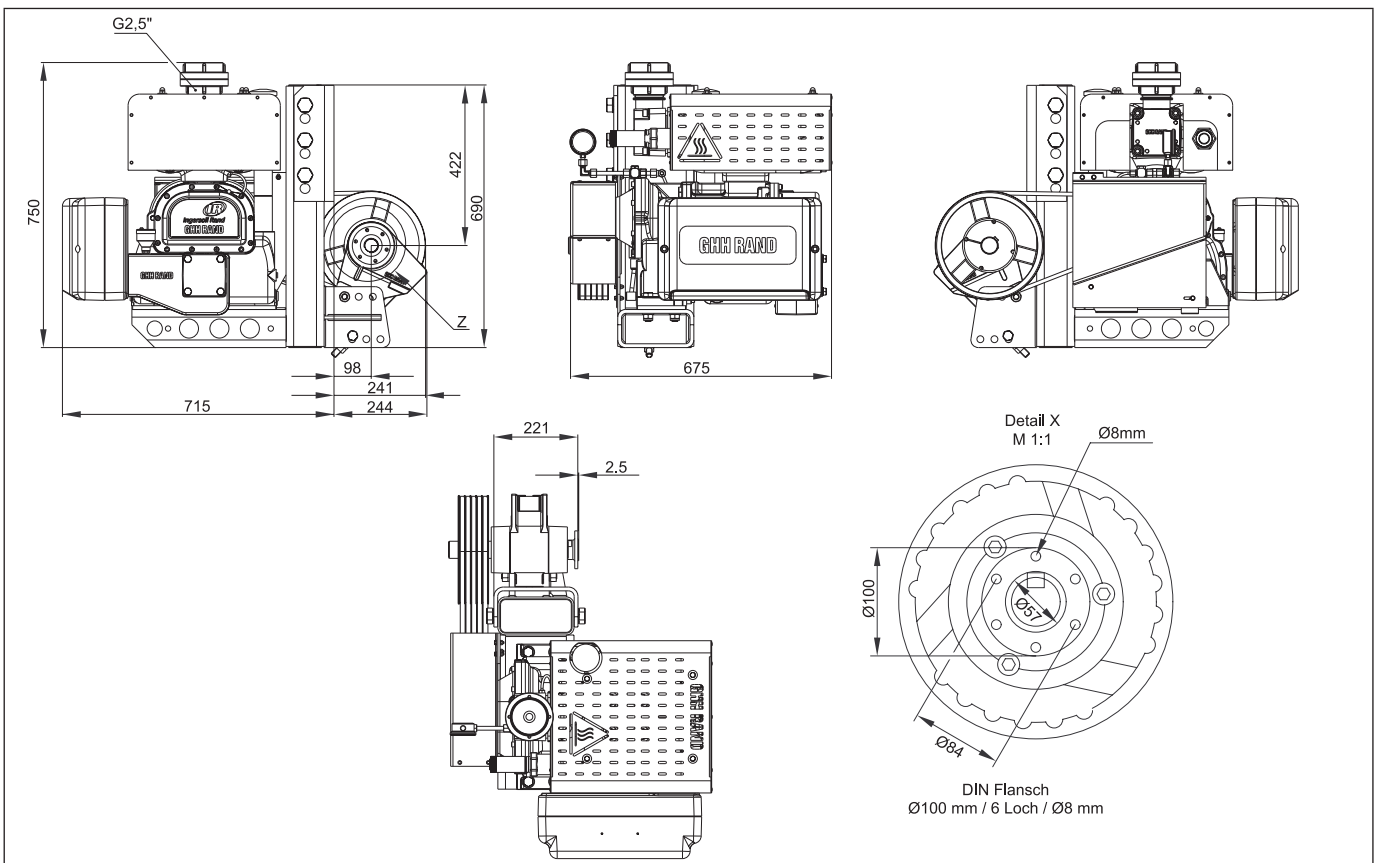

Model: L - PTO R (standard ratio)

All dimensions are approximate.

1.9 Technical data CG600 compressor unit

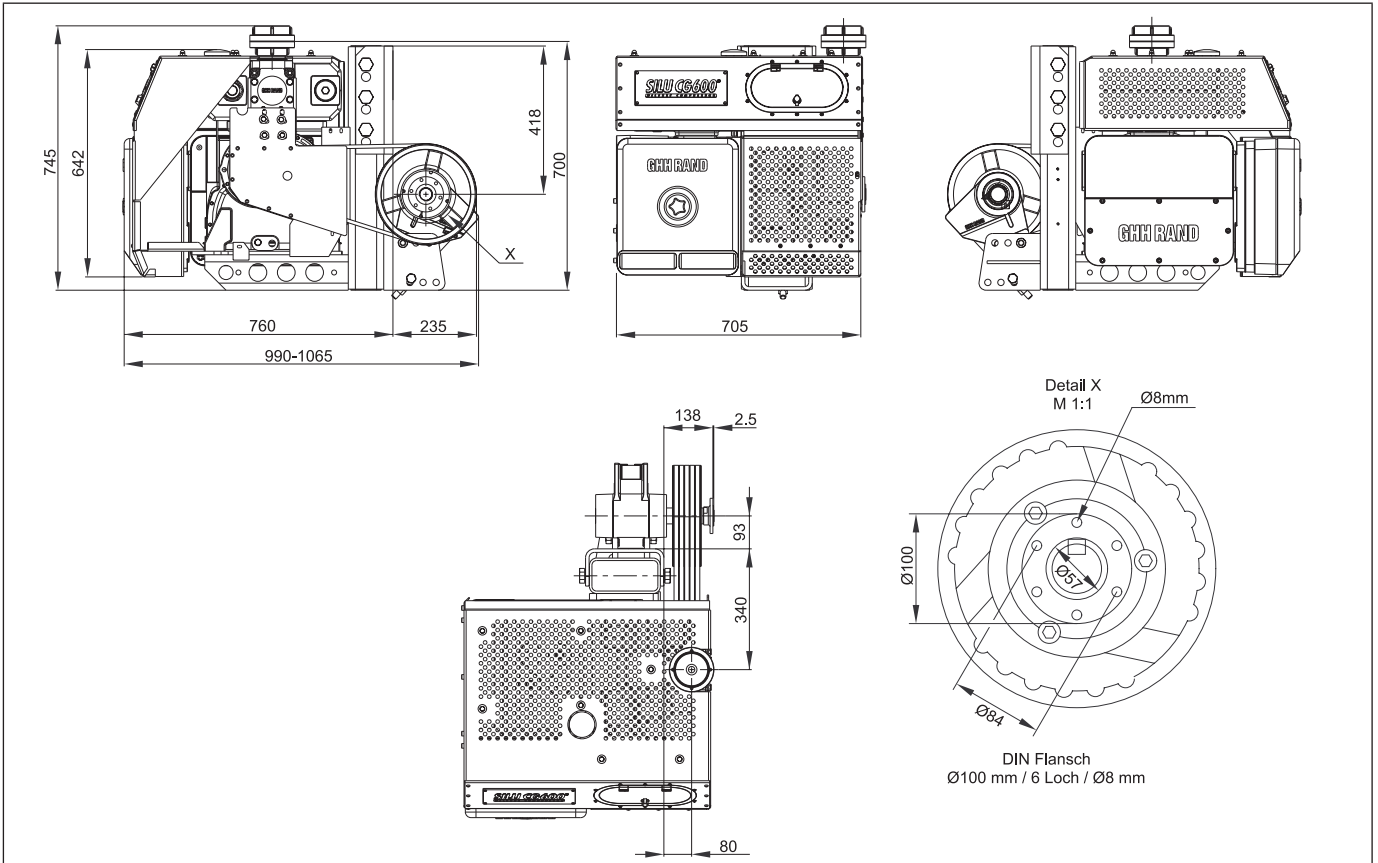

Model: R - PTO L (standard ratio)

All dimensions are approximate.

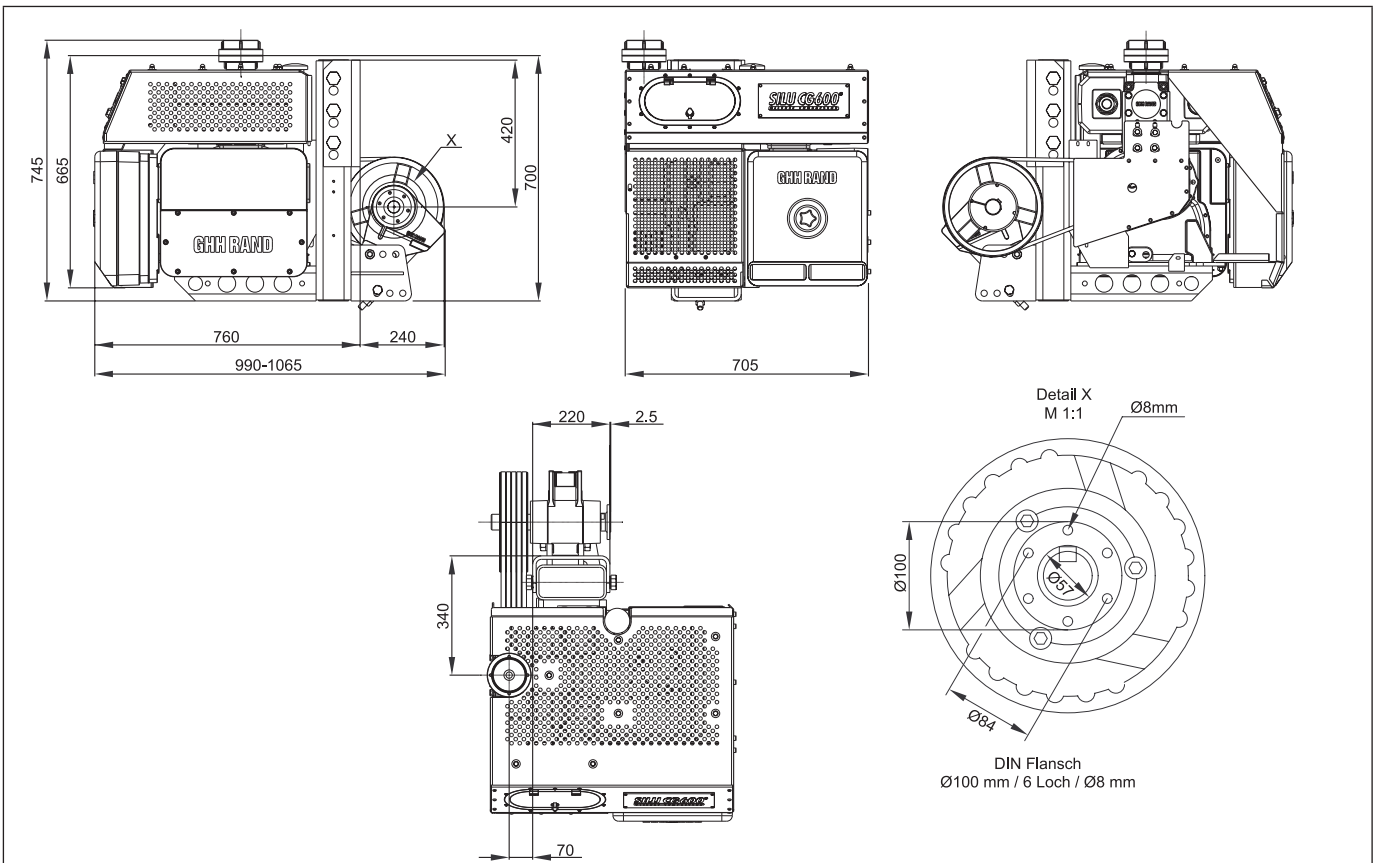

Model: L - PTO R (standard ratio)

All dimensions are approximate.

1.10 Technical data CG600 IC compressor unit

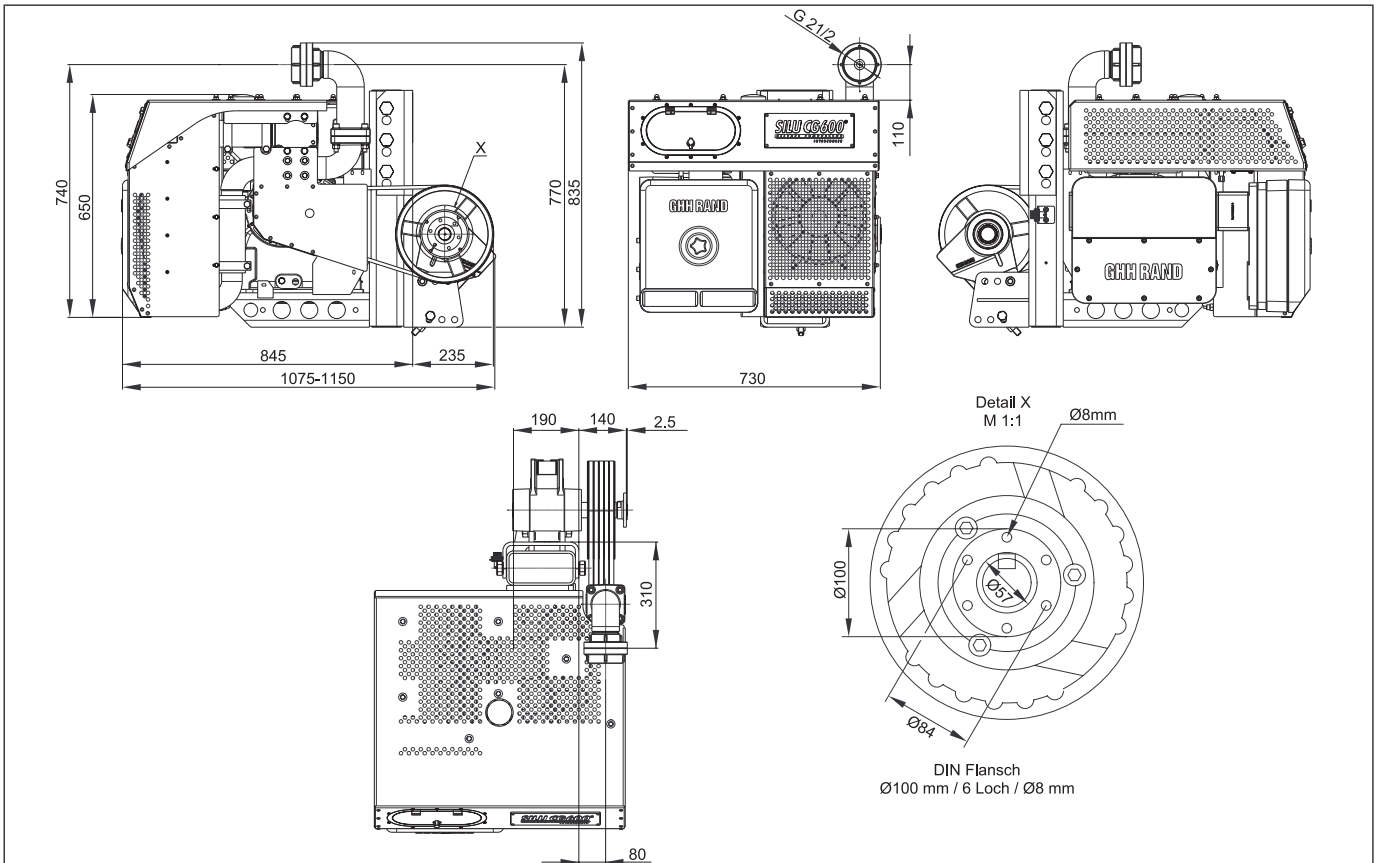

Model: R - PTO L (standard ratio)

All dimensions are approximate.

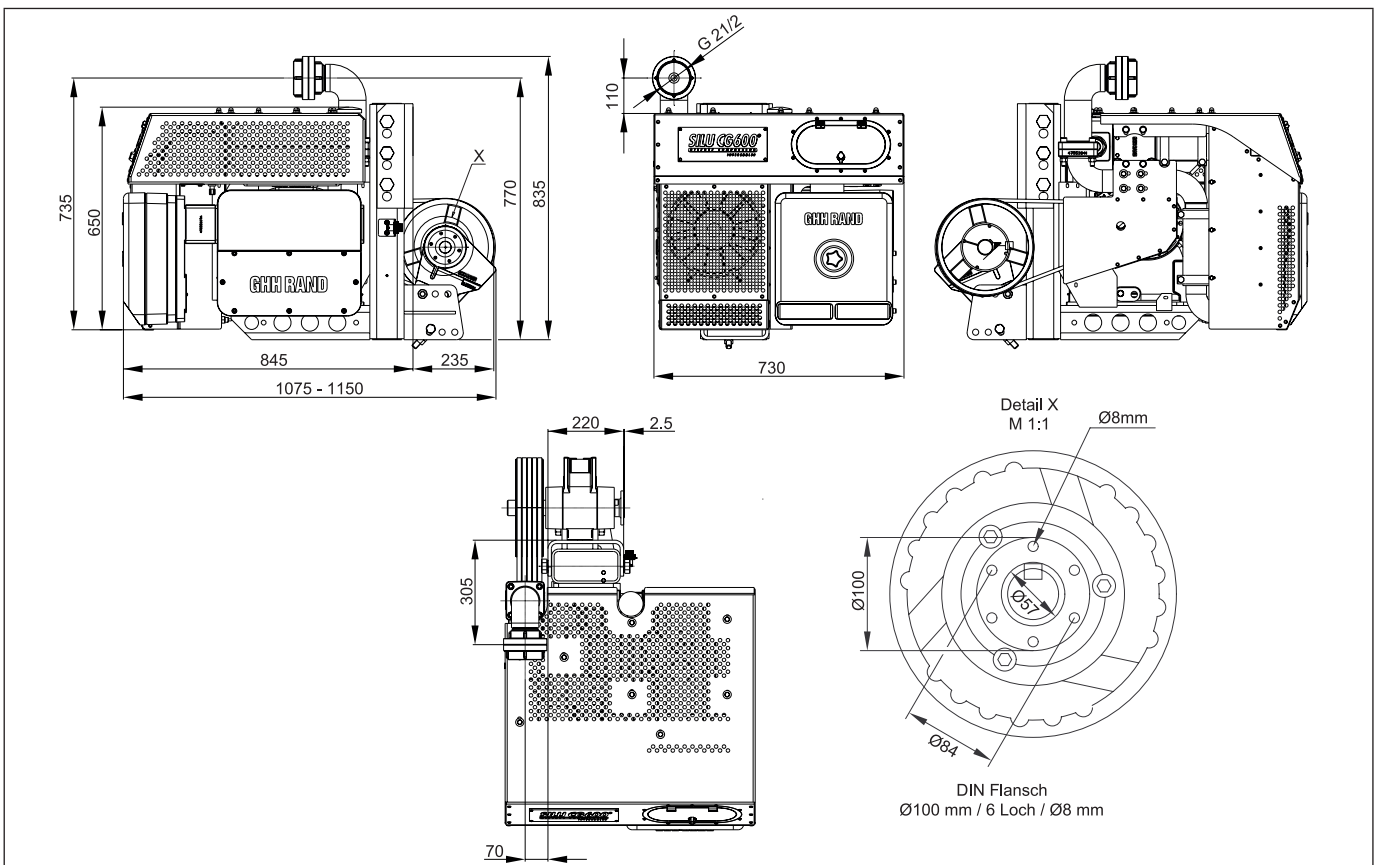

Model: L - PTO R (standard ratio)

All dimensions are approximate.

1.11 Technical data compressor unit

Dimensions & weight		CG600 LITE	CG600 STANDARD	CG600 IC
Width (approx.)	mm	675	705	730
Depth (approx.)	mm	715	760	845
Height (approx.)	mm	750	745	835
Weight (approx.)	kg	261	303	342

Speed range at standard ratio*	Unit	CG600 units		
Compressor unit drive speed	rpm	1340	1475	1600
V-belt drive transmission ratio (standard)			2.24	
CG80 compressor rotational speed	rpm	3000	3300	3600

* Transmission ratio may vary. Several V-belt drives are available from the factory for the transmission ratio (adjustable to the auxiliary drive installed in the vehicle).

NOTICE**DAMAGE TO THE COMPRESSOR!**

Exceeding the permitted speed range leads to material damage.

- ▶ Do not operate the compressor outside of its permitted speed range.

Maximum operating pressure

max. 2.5 bar

Oil filling quantity

approx. 9 litres

Maximum intake negative pressure

max. 65 mbar

Minimum oil pressure

min. 0.3 bar

Connection dimensions

Pressure joint R 2.5" external thread

Articulated shaft Only articulated shafts with two joints are permitted. Only balanced articulated shafts with a balance quality level of G 6.3 in accordance with DIN ISO 1940 with length compensation may be used.

NOTE

The performance data of the CG600 compressor unit correspond to screw compressor CG80 (*Chapter 1.7.1 on page 11*).

NOTE

More detailed information can be found in the separately available installation drawing of the compressor unit.

1.12 Operating the compressor at high altitudes

If operating the compressor at high altitudes, make sure that, depending on the existing ambient pressure, the operating overpressure must be reduced in order to prevent temperature damage to the compressor and compressor unit.

This should be carried out in accordance with the following table:

Installation height h [m]	0	1000	1500	2000	2500	3000	3500	4000	4500
Permitted operating overpressure $p_{\text{permitted}}$ [bar]	2.53	2.25	2.11	1.99	1.87	1.75	1.64	1.54	1.44

NOTICE

TEMPERATURE DAMAGE!

An ambient temperature outside the permitted range can result in damage to the compressor.

- ▶ The existing ambient temperature and intake temperature must be in the range of -20 °C to $t_{1,\text{max}}$ (for pressure difference 2.5 bar, refer to respective type of compressor) (*Chapter 1.7.1 on page 11*).

1.13 Maximum running time

The maximum permitted running time is 3 hours. Subsequently, there must be a minimum pause of 1 hour. Non-adherence to the running time can result in damage caused by overheating.

NOTE

Due to their construction, the screw compressor and the compressor unit are designed for the intermittent operation as described above. Continuous use of the compressor leads to a reduced service life. The use of an external oil cooler can improve the service life in the case of extended runtimes and extreme conditions.

1.14 External oil cooler for extreme conditions

To give the compressor an optimum service life, an external oil cooler* must be operated under the following conditions:

a) When operating in an enclosed environment (encapsulated), e.g. customer-owned direct-driven or belt-driven systems with a cover/casing, or our own electrical/diesel systems.

or

b) When operating in challenging/cramped environments, e.g. installations in the immediate vicinity of other systems/installations on the vehicle frame that are subject to heat development and/or that prevent an unimpeded supply of fresh air (e.g. vehicle exhaust systems, side plates, cladding, etc.)

or

c) For operating times that exceed the typical duration of use of standard silos (up to 5 discharges per day; typical discharge times of up to 3 hours).

or

d) When the breaks in operation between discharges are less than 1 hour.

NOTE

In order to uphold any warranty claims, maintain the highest product reliability and service life in terms of the compressor stage and lubricant, an external oil cooler must be installed and used in the specified cases.

It must be ensured that it is correctly dimensioned depending on the prevailing environmental conditions.

* The required heat dissipation of the oil cooler should be at least 4 kW @ 10 litres of oil/min. and 30 °C ambient temperature (T1 or equivalent; while observing the installation specifications of the oil cooler). For special applications, for e.g. in the case of ambient temperatures above 35 °C, the oil cooler must accordingly be designed to be larger (T2 or equivalent, while observing the installation specifications of the oil cooler).

2 Safety

2.1 General

These mounting instructions contain fundamental instructions which must be adhered to when performing assembly and installation. This mounting instruction must therefore be read in full by the responsible specialist staff before starting work.

2.2 Authorised personnel, training and qualification

Installation and assembly work must only be carried out by persons with the appropriate authorisation, training and qualifications, who are familiar with the valid safety regulations.

Repairs or modifications must only be performed by authorised personnel who is available at any time at the service sites or at GHH RAND.

2.3 Safety-conscious work

The safety-related regulations that are relevant for the installation, operation and maintenance of air compressors can be found in the following publications:

Machinery Directive 2006/42/EC

Standards, in particular:

DIN EN ISO 12100-1/2	Safety of machinery
DIN EN 1012-1	Compressors and vacuum pumps, safety requirements

The regulations of the professional associations, in particular:

BGI 666	Sample operating instructions for operation of container vehicles for granular or dust-like goods (silo vehicles).
---------	--

In this context, the respectively last applicable versions of these regulations shall be authoritative. Special legal provisions and regulations, particularly safety regulations, that may apply in your company or due to local conditions must also be adhered to. In case of competing regulations, the more restrictive provisions shall be applied. You must also observe any national regulations in the respective country of use.

2.4 Safety instructions for the owner/operator

The owner/operator is responsible for ensuring that the screw compressor is in a safe operational condition. Damaged or faulty parts must be immediately replaced. If the screw compressor is used to convey combustible materials, make sure that the temperature remains below the spontaneous ignition temperature for any dust/air mixture which may be created. In accordance with the professional association regulation BGI 666, for the pneumatic transport of materials subject to dust explosion, a temperature limit of max. 120 °C must be adhered to (measurement point before contact with the materials to be conveyed).

2.5 Unauthorised conversions and spare parts

Conversions and modifications to the screw compressor and screw compressor unit are not permitted. In the event of damage to the lead seal, any warranty claims are invalid.

Original replacement parts and accessories that are authorised by the manufacturer represent safety factors. The use of non-original or unauthorised replacement and accessory parts may void the liability for resulting consequences.

2.6 Incorrect operating methods

WARNING

INCORRECT OPERATING METHODS!

The operation of the compressor under incorrect conditions may lead to serious injuries and significant material damage.

- ▶ The compressor must only be operated under permitted conditions.

Unless approval is obtained from GHH RAND, the compressor must only be operated under the conditions stated in *Chapter 1.7 on page 9* to *Chapter 1.14 on page 18*.

2.7 Disposal

Compressor components, as well as operating materials used in conjunction with the screw compressor and compressor unit must be disposed of observing the local regulations.

3 Installation guidelines

NOTE

Also observe the safety instructions in *Chapter 2 on page 19*.

3.1 Internal transportation

3.1.1 Internal transportation of the screw compressor

The screw compressor and the accessories are delivered separately.

The screw compressor is on a pallet and secured with straps.

The accessories are delivered in a separate box.

⚠ WARNING

RISK OF TIPPING OVER IF TRANSPORTED ON THE GROUND!

If using internal transport with insufficiently dimensioned transportation equipment, there is a risk of tipping over and injuries.

- For internal transportation, use a sufficiently dimensioned lifting truck or fork lift.

For transportation of the screw compressor using a crane, an eye bolt **(1)** can be screwed into the specified slinging point V (*Chapter 1.7 on page 9*, slinging point V).

⚠ WARNING

RISK OF FALLING IF TRANSPORTED USING A CRANE!

Serious injuries, including death, are possible if the screw compressor falls when transporting using a crane.

- Use sufficiently dimensioned lifting accessories.

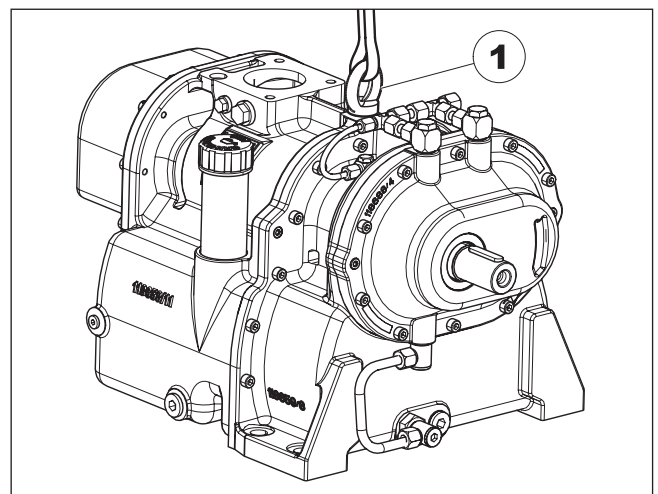

3.1.2 Internal transportation of the unit

The compressor unit (1) is fastened to a euro-pallet (2). For transportation, use a sufficiently dimensioned lifting truck/fork lift.

⚠ WARNING

RISK OF TIPPING OVER IF TRANSPORTED ON THE GROUND!

If using internal transport with insufficiently dimensioned transportation equipment, there is a risk of tipping over and injuries.

- ▶ For transportation, use a sufficiently dimensioned lifting truck or fork lift.

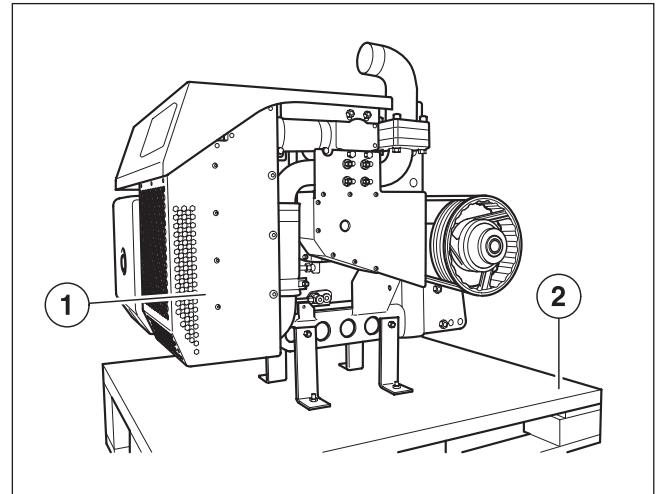

3.2 Drive

3.2.1 V-belt drive

The V-belt drive is primarily used for installation in a vehicle with drive via the vehicle engine.

Thereby, the power consumption of the screw compressor from the power take-off of the vehicle engine is provided as continuous power. The V-belt drive absorbs the rotary oscillations and vibrations generated by the vehicle engine and prevents transmission to the drive shaft of the compressor.

Moreover, the impacts from engaging the power take-off are also dampened.

V-belts and V-belt pulleys

GHH RAND uses V-belt pulleys with a balance quality level of G 6.3, in accordance with DIN ISO 1940-1, balanced using the "half feather key" method in accordance with DIN ISO 8821. The balance quality level of G 6.3 must also be selected by the third-party manufacturer, which designs and manufactures its compressor unit based on the CG80 compressor stage.

Min. Ø of the V-belt pulley:

125 mm

Permitted radial force $F_{r_{max}}$

5000 N

NOTE

Design, installation and maintenance of the V-belt drive must be carried out in accordance with the regulations and instructions from the respective manufacturer or supplier.

NOTE

The GHH RAND compressor units are supplied with the drive installed.

3.2.2 Articulated shaft

The V-belt drive is usually carried out through an articulated shaft between the power take-off of the vehicle drive and bearing block (bearing of the belt pulley).

Selection of articulated shaft

Consider the following items during the determination of the articulated shaft:

- Determine the length of the articulated shaft considering the installation dimensions while paying attention to the maximum permitted expansion length.

NOTICE

DAMAGE TO THE COMPRESSOR DRIVE!

Incorrect installation of the articulated shaft can result in damage to the compressor drive.

- ▶ For the maximum permitted extension length of the articulated shaft, refer to the operating manual of the manufacturer of the articulated shaft and maintain during installation.

NOTE

The selection of the articulated shaft should only be made after the test mounting of the compressor on the vehicle (*Chapter 3.7.1 on page 32*), since this is how the precise installation location of the compressor is determined.

The overall inclination angle α of the articulated shaft must not exceed 12° .

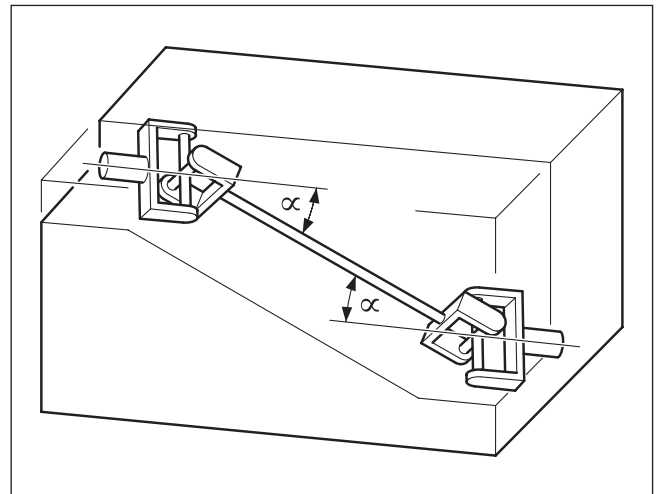

3.2.3 Direct drive

NOTE

For more information about other drive options for the compressor, please contact GHH RAND.

3.3 Installation and position

The compressor unit must be connected to the vehicle frame using a mounting console (retaining device). If a mounting console not supplied by GHH RAND is used, the dynamic load resulting from the weight of the compressor and attachment parts and the condition of the road must be taken into account when designing it.

In addition, observe the regulations and instructions from the respective vehicle manufacturer.

The screw compressor has a foot attachment. It must be installed on a level, torsion-free base. The screw compressor must be screwed to the console at all 4 attachment points provided (*Chapter 1.7 on page 9*).

3.3.1 Permitted inclination

NOTICE

INSUFFICIENT LUBRICATION!

Excessive inclination results in irregular level of lubricant in the housing.

- ▶ Observe the maximum permitted inclination of the screw compressor during operation:
 - To the front and to the rear: 10°
 - To the right and left: 10°

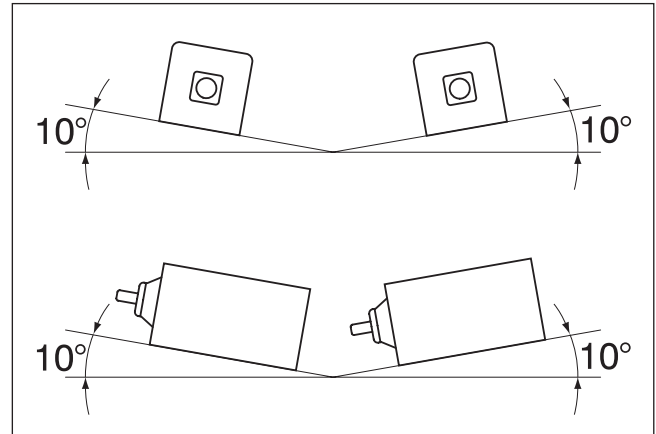

3.4 Preparing installation

The approximate position of the compressor and the compressor unit on the vehicle must be determined prior to the installation considering the following framework conditions.

Accessibility to the oil pressure gauge, negative pressure indicator, oil dipstick or oil inspection glass, oil drain plug or oil intake strainer must be taken into consideration during installation.

NOTE

The exact position of the compressor unit on the vehicle can only be determined in the course of a trial assembly after completing the compressor unit.

3.4.1 Required space conditions for the unit

Check the space required on the truck on the right-hand side (in the direction of travel), taking into consideration the respective unit dimensions.

Dimensions of the line of products, see *Chapter 1.8 on page 13* to *Chapter 1.11 on page 16*.

3.4.2 Checking the direction of rotation

Observe the permitted direction of rotation of the compressor is according to the arrow mark O (*Chapter 1.7 on page 9*) on the compressor housing (clockwise, viewed looking towards the drive journal).

3.4.3 Checking the direction of rotation of the unit

Check to ensure that the direction of rotation of the compressor unit model (as ordered) matches the direction of rotation of the vehicle's power take-off (viewed in the direction of travel).

If the power take-off rotates in anti-clockwise direction, install the unit in **R - PTO L version**.

If the power take-off rotates in clockwise direction, install the unit in **L - PTO R version**.

3.4.4 Aligning the compressor unit on the vehicle/flange parallelism

Installation and alignment of the compressor unit must be carried out so that the articulated shaft flange installed on the bearing block is aligned parallel to the articulated shaft flange of the power take-off.

NOTICE

DAMAGE TO THE BEARING!

Non-observance of attachment, flange parallelism and angle of inclination of the articulated shaft can result in significant bearing loads, with the result of premature damage to the bearing.

- Fundamentally, the structural guidelines from the manufacturer of the respective vehicle and technical information provided by the manufacturer of the articulated shaft with regard to attachment, flange parallelism and angle of inclination of the articulated shaft must be adhered to.

NOTE

To ensure flange parallelism, the compressor unit may have to be installed at a slight angle (side view) or any existing frame inclination, frame offset or auxiliary frame must be compensated for by using special adapters, shims or chocks.

Special adapters can be obtained from GHH RAND for various vehicle types and positions. For more information, please contact GHH RAND.

3.4.5 Air flow CG600 IC

The air flow for the cooling fan on the IC unit must be able to circulate freely and may not be affected by cover plates, etc.

The air intake fitting of the compressor unit may not be in the area of the hot exhaust outlet. If necessary, move the exhaust system of the vehicle engine or the suction range of the compressor unit (e.g. back roof intake).

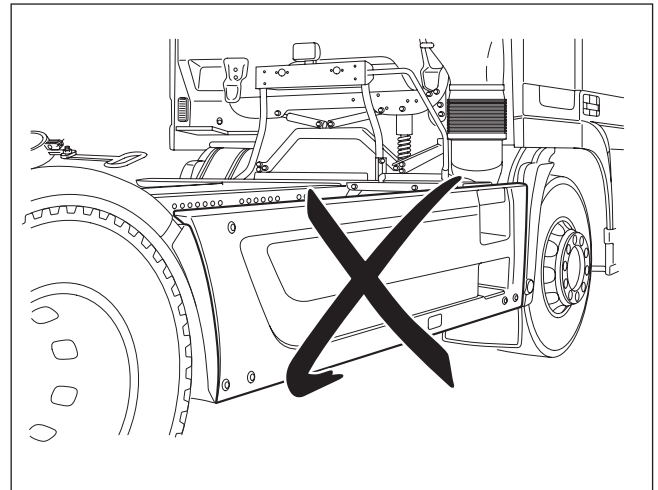

NOTICE

INSUFFICIENT FRESH AIR SUPPLY!

For vehicles with side cladding installed, the side cladding must be folded down or removed before switching on the compressor unit in order to prevent temperature damage to the compressor.

- Ensure sufficient fresh air supply.

3.5 Observe the tightening torques

The tightening torques are specified in the following chapters.

⚠ WARNING

INCORRECT TIGHTENING TORQUE!

An incorrect tightening torque can endanger the secure attachment of the compressor, or result in damage to components due to excessive tightening torque.

- The specified tightening torques must be observed.

3.6 Completion of the screw compressor

NOTICE

FOREIGN OBJECTS IN THE COMPRESSOR!

If foreign objects enter the screw compressor during completion, the screw compressor will be destroyed when it is started up.

- ▶ Make sure that no foreign objects enter the screw compressor.

3.6.1 Installing the hose connection flange (example)

NOTE

The following is an exemplary description of the installation of the hose connection flange on the screw compressor, installation for the CG80 and CG600 is analogous.

- ▶ Attach the hose connection flange (2) with the seal (1) to the compressor connection flange using screws (4) and retaining washers (3).
- ▶ Initially, hand-tighten the screws (4) diagonally, subsequently fully tighten diagonally to the required tightening torque.

Tightening torque (M12 A2-70): 65 Nm

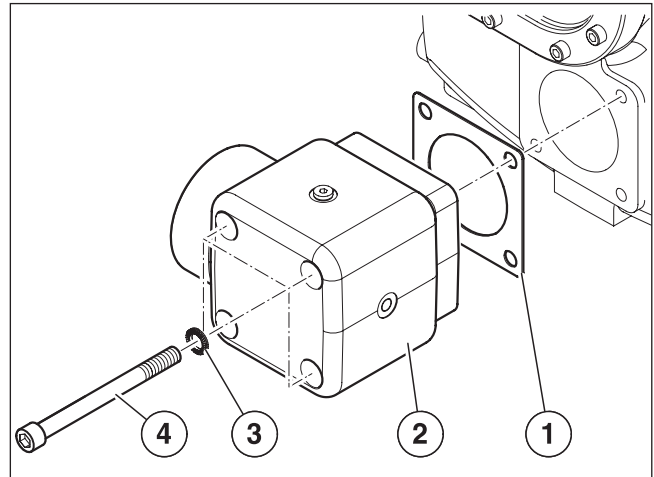

3.6.2 Installing the maintenance indicator on the hose connecting flange

NOTICE

UNSUITABLE INSTALLATION TOOLS!

The maintenance indicator can become damaged if unsuitable tools are used during installation.

- ▶ Do not use pliers or lever tools to install the maintenance indicator.

The maintenance indicator can be installed as illustrated, accessibility must be considered during installation.

- ▶ Firmly screw in the double nipple (2) supplied into the connection provided on the hose connecting flange (1).
- ▶ Firmly screw the maintenance indicator (3) manually onto the double nipple.

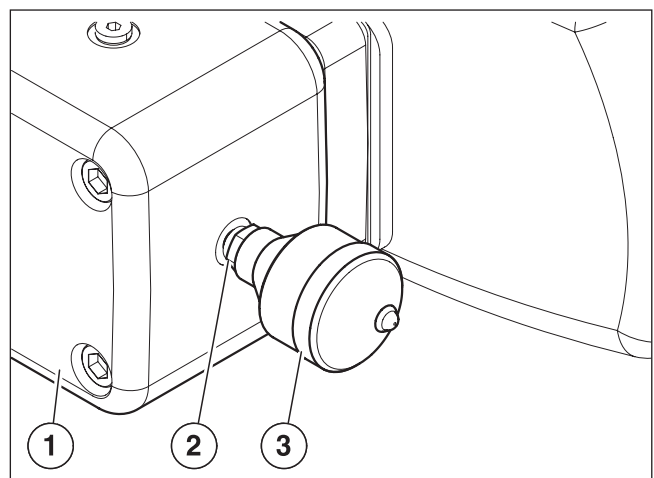

3.6.3 Installing the oil pressure gauge

NOTICE

HIGH OPERATING TEMPERATURES!

The oil pressure gauge can be damaged if it is exposed to ambient temperatures greater than 60°C.

- ▶ Do not install the oil pressure gauge close to hot parts or in the exhaust area of the safety valve.
- ▶ When installing, make sure that there is a minimum distance of 5 cm between it and the discharge silencer and other hot components.

The oil pressure gauge can be installed as illustrated, accessibility must be considered during installation.

- ▶ Shorten the hydraulic pipe (2) as required and install onto the T-fitting (1) (*Chapter 1.7 on page 9, connection option H*).
- ▶ Install the angle fitting (3) and oil pressure gauge (4) supplied in accordance with the above instructions.

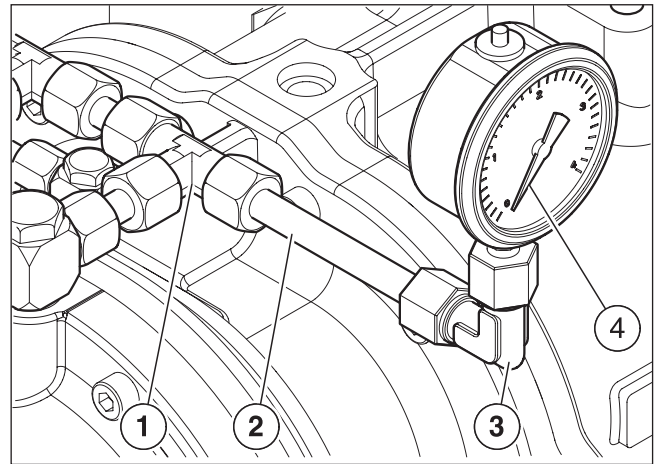

3.6.4 Oil cooler connection on the compressor (optional)

The screw connections for connecting the oil lines to the oil cooler should be attached before vehicle assembly. The position and size of connections Q and R indicated in *Chapter 1.7 on page 9*.

The external oil cooler is operated via the fan controller (*Chapter 3.8.1 on page 37*) and the required oil pressure switch (6). The oil pressure switch (6) must be integrated in the pipeline to the external oil cooler (*Chapter 1.7 on page 9, connection option Q*) using a suitable screw connection (5).

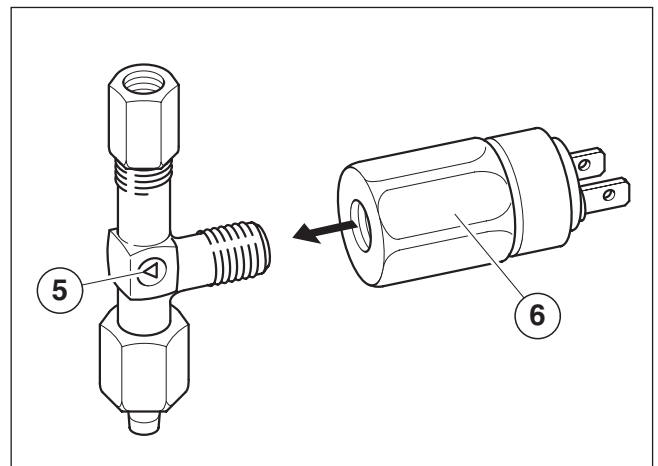

NOTE

Units ordered from GHH RAND for external oil cooler operation are pre-equipped with the corresponding screw connections.

For third-party units based on the CG80 compressor stage, the standard connection between connections Q and R must be removed.

3.6.5 Installing the intake silencer and air filter

The air filter and combined intake silencer (with integrated air filters) for the compressor available from GHH RAND must be suitably dimensioned with regard to the noise emission and filter capacity of the application on the silo vehicle.

When selecting air filters or combined intake silencers not supplied by GHH RAND, observe the following:

- Overall degree of separation η :
 η SAE roughly $\geq 99.5\%$
 Rated flow in accordance with the intake volume flow of the respective type of screw compressor.
- A paper filter should be selected as the filter material.

NOTICE

FILTER MATERIAL AND FILTER DESIGN UNSUITABLE!

Unsuitable filter material, as well as an insufficiently dimensioned filter can result in destruction of the screw compressor.

- ▶ Only use paper filter with the specified degree of separation.
- ▶ The max. permitted intake negative pressure is 65 mbar.

- ▶ The suction silencer/filter must be reliably protected against ingress of water (e.g. spray) and greater quantities of dirt.

NOTICE

INCORRECT INSTALLATION POSITION OF THE AIR INTAKE!

Damage due to the temperature and contamination of the goods to convey can occur if the air intake is located in the area of warm air or the discharge of hot exhaust gases.

- ▶ The air intake must not be located in the area of warm air or emitted hot exhaust fumes.
- ▶ If necessary, the exhaust system of the vehicle or the installation location of the air filter must be moved.

3.6.6 Mounting the discharge silencer

CAUTION

NOISE GENERATION!

Excessive noise exposure can lead to health problems.

- ▶ A discharge silencer is used to reduce the noise level. Further measures for reducing the noise level on the system side are recommended.
- ▶ During operation, always wear suitable ear protection.

If using a discharge silencer with damping material, make sure that the damping material cannot ingress into the conveying air.

Damping material made from stainless steel ensures this long-term. GHH RAND supplies effective discharge silencers without damping material.

Install the discharge silencer directly on the pressure joint.

The seal between the discharge silencer and compressor must be temperature-resistant (min. 400 °C).

The nominal width of the exhaust must not be reduced (increased noise emission, pressure loss).

⚠ WARNING

DANGER OF BURSTING!

An incorrectly dimensioned discharge silencer can burst or result in damage to the compressor due to the temperature.

- ▶ When selecting and designing the discharge silencer, make sure that it features a minimal pressure loss.
- ▶ The silencer must be suitable for the pressures used.

Installing the discharge silencer (example)

NOTE

The following is an exemplary description of the installation of a discharge silencer.

- ▶ Attach the discharge silencer (1) with the seal (3) to the connection flange of the screw compressor (2) using screws (4), plain washers (6) and a split washer (5).
- ▶ Initially, hand-tighten the screws (4) diagonally, subsequently fully tighten diagonally to the required tightening torque.

Tightening torque (M12 A2-70): 65 Nm

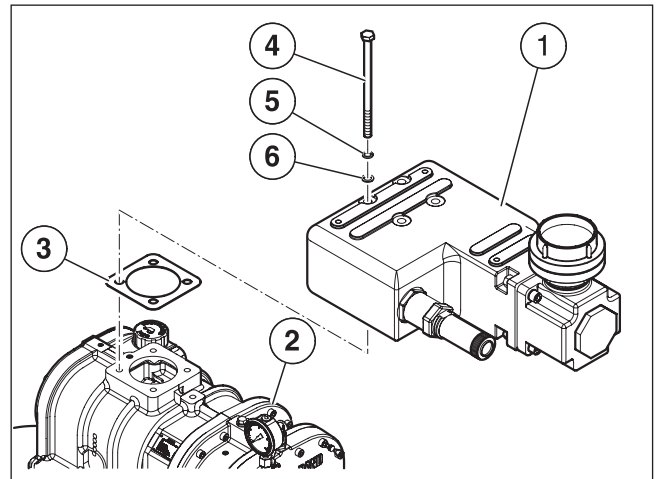

⚠ CAUTION

HOT SURFACES!

During operation, the screw compressor and discharge silencer are very hot. There is a risk of burning.

- ▶ Appropriate measures to screen the hot surfaces must be taken by the installation manufacturer.

3.6.7 Installing the safety valve

NOTE

When installing a safety valve, observe the manufacturer instructions.

The safety valve (overpressure valve) is used as a safety mechanism for the compressor.

In order to prevent the operating pressure from increasing to impermissible levels, it should be of an encapsulated design.

NOTICE

IMPERMISSIBLE OPERATION OF THE SAFETY VALVE!

There is a risk of damage to the compressor if the safety valve is operated as a discharge/control valve.

- ▶ Do not use the safety valve as a discharge/control valve.

When using discharge silencers not supplied by GHH RAND, observe the following:

The safety valve **(2)** must be installed close to the pressure joint and between the screw compressor and the non-return valve/non-return flap, e.g. in the discharge silencer **(1)**.

The permitted response pressure of the safety valve can be a maximum of 0.1 bar more than the max. operating pressure.

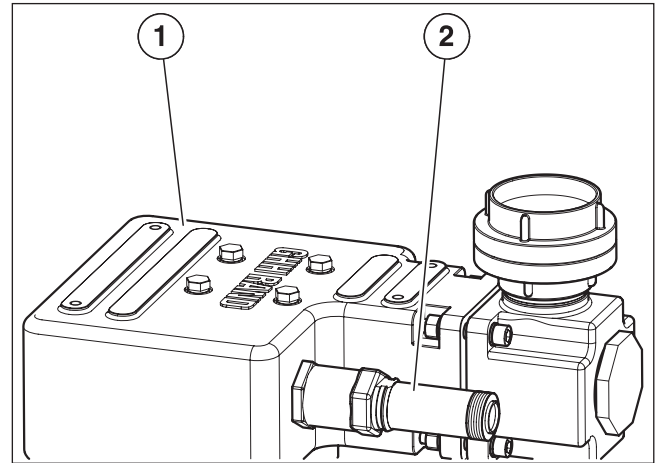

NOTICE

INCORRECT DIMENSIONING OF THE SAFETY VALVE!

An incorrectly dimensioned safety valve can result in damage to the compressor.

- ▶ The safety valve must be dimensioned so that, in the event of a blockage in the line (e.g. jammed non-return valve), the air volume flow on the pressure side can be reliably discharged.
- ▶ The permitted response pressure must not be exceeded.

The safety valve from GHH RAND must only be installed as illustrated (0° ... 90°):

NOTICE

INCORRECT INSTALLATION POSITION OF THE SAFETY VALVE!

An incorrect installation position of the safety valve can result in destruction of the compressor.

- ▶ The safety valve must only be installed at an angle of 0° (vertical) to 90° (horizontal).

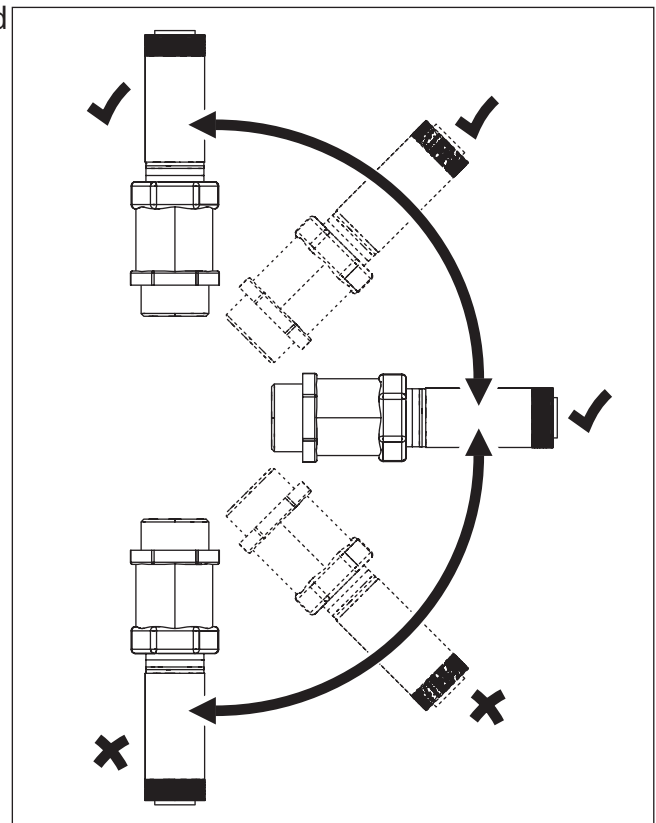

3.6.8 Installing the non-return valve

To protect the compressor, a non-return valve (or non-return flap) must be installed in the pressure line, close to the compressor.

The non-return valve (or non-return flap) should prevent the compressor from running backwards for a long time. It is not used to prevent material blow-backs.

The discharge silencers supplied by GHH RAND have an integrated non-return valve (or an integrated non-return flap).

NOTE

To prevent unintended material rebound, it is obligatory to install an additional non-return valve (or a non-return flap) in the pneumatic system of the silo construction.

3.6.9 Installing the oil dipstick

- ▶ Screw in the oil dipstick (1).

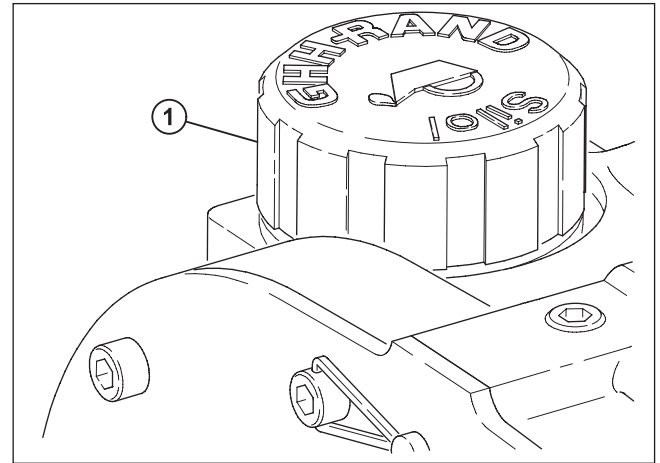

3.6.10 Installing the screw compressor on the mounting console (third-party manufacturer)

- ▶ Install the screw compressor on the mounting console taking the installation position into account (*Chapter 3.3 on page 23*).

At least four fastening screws (min. screw size: M16 8.8, hexagon screw with shaft) must be used.

- ▶ First tighten the fastening screws cross wise by hand.
- ▶ Tighten the fastening screws to the required tightening torque.

Tightening torque (M16 8.8): 214 Nm

⚠ WARNING

INCORRECT TIGHTENING TORQUE OR WRONG SCREW TYPE OR STRENGTH CLASS!

An incorrect tightening torque or the wrong screw type or strength class can endanger the secure attachment of the screw compressor, or result in damage to components due to excessive tightening torque.

- ▶ The specified tightening torques must be observed.
- ▶ Use the screws provided.

3.6.11 Installing the pressure line

Avoid reducing the nominal diameter of the outlet. The pressure line must be routed to the consumer as straight as possible and so that it is not under tension.

To prevent impact sound from being transferred and pipelines from moving between the discharge silencer and the subsequent pressure line, install a temperature-resistant expansion joint.

NOTE

When installing seals, fittings and flexible pipelines, make sure that the components have the appropriate thermal stability.

DANGER
RISK OF EXPLOSION!

The pressure line must be designed (geometry/material) so that the hot compressed air cannot ignite the conveyed material. In accordance with the professional association regulation BGI 666, for the pneumatic transport of materials subject to dust explosion, a temperature limit of max. 120 °C must be adhered to (measurement point before contact with the materials to be conveyed). It is therefore advisable to use a compressed air aftercooler to ensure a suitable conveying air temperature within the pneumatic system.

- ▶ Do not exceed the temperature limit at the measurement point before contact with the materials to be conveyed.

3.7 Completion of the compressor unit

3.7.1 Test mounting of the compressor unit

To determine the exact installation position on the vehicle frame and the fastening bores in the adapter, it is necessary to position the compressor unit with adapter on the vehicle frame with the assembly console. It must be checked in this installation position whether all attachment parts can be mounted without problem and in accordance with the installation guidelines.

NOTE

The unobstructed outlet of cooling air must be guaranteed for the IC unit (*Chapter 3.4.5 on page 25*).

NOTE

It may be necessary to install lines, hoses, etc. fastened on the vehicle frame once again before mounting the compressor unit. The vehicle frame must remain free at the planned attachment location of the compressor unit.

NOTE

In order to achieve parallel alignment of the flange, the adapter must be aligned according to the vehicle frame (*Chapter 3.4.4 on page 24*).

NOTE

In order to achieve an optimal articulated shaft angle or to not exceed the maximum permitted articulated shaft angle ($\alpha = 12^\circ$, *Chapter 3.2.2 on page 23*), the possibility of adjusting the bearing block must be taken into account in the test mounting (*Chapter 3.7.3 on page 35*).

- ▶ Using a forklift or lifting truck, drive the pallet with the compressor unit **(1)** and mounting console **(2)** carefully under the vehicle frame, until the adapter lies on the vehicle frame.
- ▶ Lift the pallet with the compressor unit carefully until the desired installation position is reached. Here, make sure that the compressor unit **(1)** does not touch the vehicle frame.

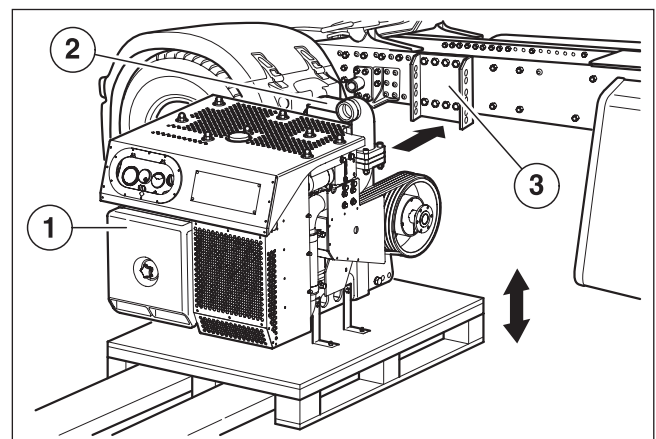

NOTE

The upper edge of the adapter should be at least at the height of the upper edge of the vehicle frame. In order to achieve an offset, the adapter can be dismantled, turned by 180° and remounted.

- ▶ Make sure there is sufficient floor space for a full load.

Once you have determined the correct installation position, the holes for the mounting of the adapter on the vehicle frame should be determined as follows:

- ▶ For a pre-drilled vehicle frame, transpose the drill pattern of the vehicle frame to the backside of the adapter.

NOTICE

SUFFICIENT DIMENSIONING OF THE DRILL HOLES!

Fit the mounting console with at least six drill holes Ø 14.5 mm (min. screw size: hexagon screw with shaft M14 10.9 with the corresponding washer and self-locking nut).

- ▶ Preferably use the screw connections recommended by the vehicle manufacturer for load-bearing frame mounts.
 - ▶ The placement of the hole pattern can be different based on the respective vehicle frame. Use the largest hole spaces.
- ▶ If the vehicle frame was not drilled (sufficiently) at the factory, initially drill holes according to the vehicle manufacturer's installation guidelines and the dimensions of the adapter on the vehicle frame. Transpose the hole patterns of the vehicle frame onto the backside of the adapter.

NOTICE

INSUFFICIENT REINFORCEMENT OF THE ATTACHMENT AREA!

The compressor unit can fall down due to insufficient reinforcement and cause damage to the frame (cracking).

- ▶ Reinforce some vehicle frames where the compressor unit is fitted in accordance with the manufacturer's installation guidelines.

NOTICE

DAMAGE TO THE VEHICLE FRAME!

The vehicle frame warps or is damaged.

- ▶ Welding work must not be performed on the vehicle frame.
- ▶ Holes must only be drilled in the vehicle frame in accordance with the instructions in the manufacturer's installation guidelines.

- ▶ Lower the pallet and remove the compressor unit from the vehicle.
- ▶ Loosen the screws (2) and remove the adapter (1) from the mounting console.
- ▶ Drill holes for the fastening screws according to the markings on the adapter (1).

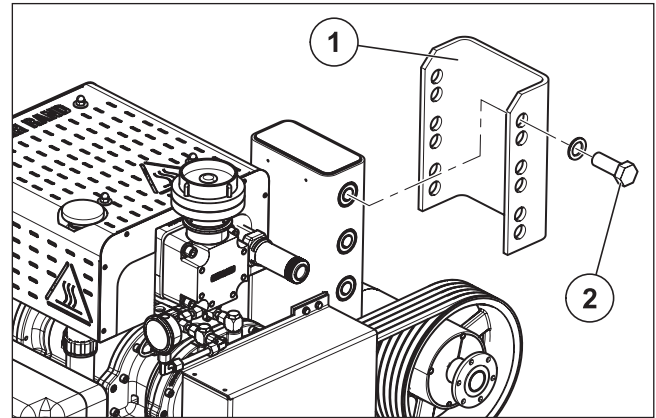

3.7.2 Installing the compressor unit

- ▶ Position the adapter on the vehicle frame as determined in the test mounting (*Chapter 3.7.1 on page 32*).
- ▶ Screw the adapter (1) to the vehicle frame (2) using screws (3).

Tightening torque (M14 10.9): 193 Nm

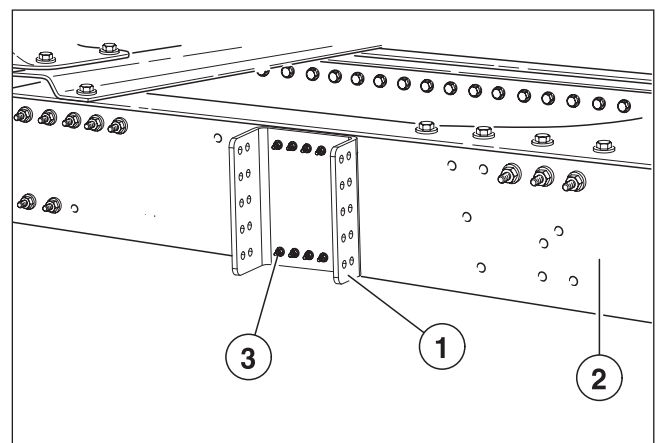

- ▶ Lift the pallet including the compressor unit (1) using a forklift or lifting truck.
- ▶ Align the compressor unit (1) with the mounting console (2) in the adapter (3) which was previously fitted to the vehicle frame.
- ▶ Check the alignment according to the installation guidelines.

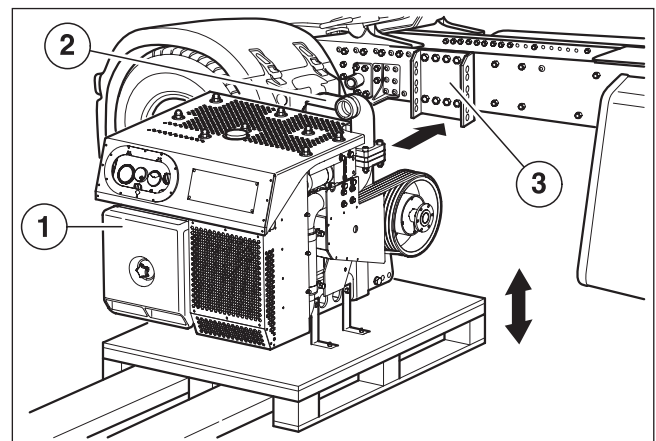

- ▶ After the alignment, screw the mounting console (2) of the compressor unit (1) to the adapter (3) with three screws (4) M24x60, strength class 8.8 and wedge locking washers (5) on both the left and right.

Tightening torque (M24 8.8): 720 Nm

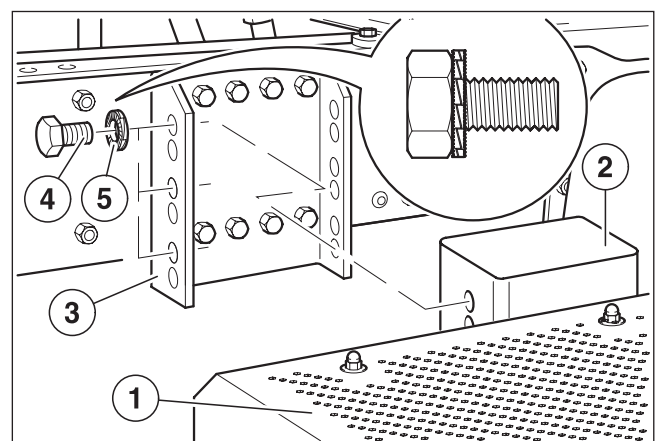

- ▶ Separate the compressor unit from the pallet (1) by unfastening the four screw connections (2).

CAUTION

RISK OF CRUSHING!

There is a risk of crushing if the compressor unit falls down.

- ▶ Support the pallet with the lift truck or forklift until the four screw connections have been unfastened and removed from the pallet.

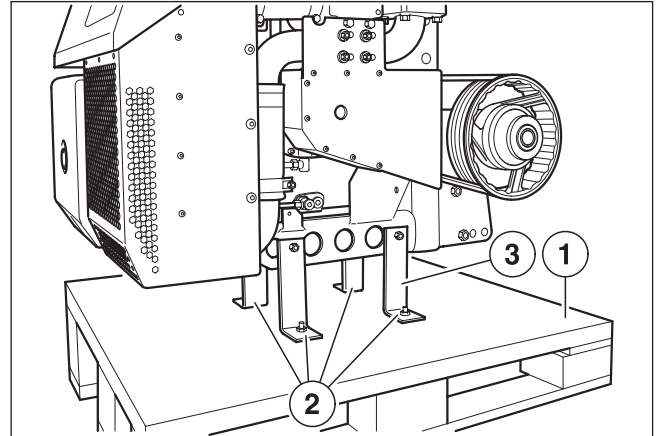

- ▶ After the four screw connections (2) have been unfastened, lower the pallet and then remove the fork lift or lift truck.
- ▶ Remove the holders (3) from the compressor unit.

3.7.3 Installing the articulated shaft

CAUTION

RISK OF INJURY DUE TO ROTATING PARTS!

If the rotating parts are not adequately covered, there is a risk of injury.

- ▶ Provide a cover for the articulated shaft in accordance with accident prevention regulations.

The vehicle's auxiliary drive flange (1) and the V-belt flange (3) can be aligned to each other in order to comply with the max. permitted articulated shaft angle by moving the bearing block (4).

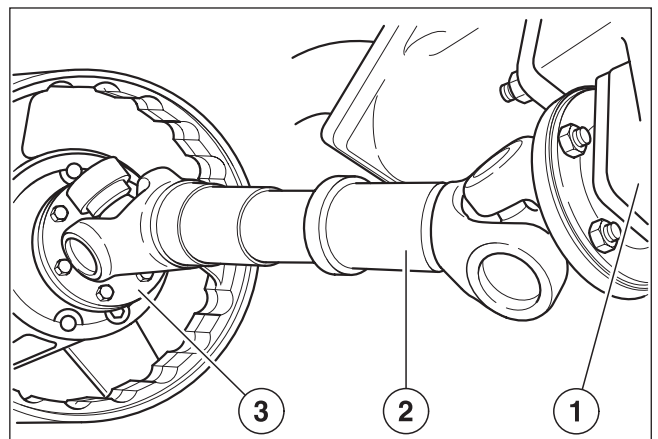

NOTE

The swivel bearing of the bearing block (4) is installed in the inner position (a) as standard. If position (b) or (c) is used, longer V-belts must be used accordingly, so that the optimum tension length is available.

The bearing block clamping position (d, e, f) must be adjusted according to the change in swivel bearing position (a, b, c). The length of the V-belts must also be adjusted when changing the V-belt transmission ratio. Never use a V-belt type other than the specified SPA/XPA type.

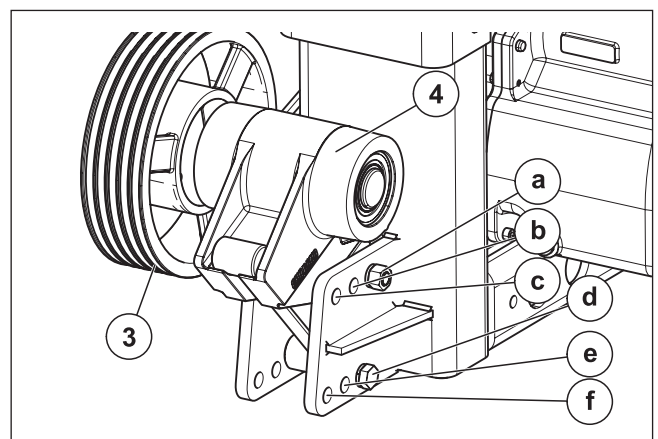

NOTICE**DAMAGE TO THE COMPRESSOR!**

Incorrect selection of the V-belt can cause damage to the compressor.

- ▶ Use the correct V-belt length and V-belt type. Contact GHH RAND if necessary.

- ▶ Check the alignment of the V-belt pulley.

NOTE

For an optimal service life of the V-belt drive, the alignment of the V-belt pulleys must be checked after moving the bearing block.

The V-belt drive is supplied pre-adjusted. If necessary, the screw compressor must be aligned with the bearing block using the play in its foot attachment.

Align the V-belt pulleys to each other before commissioning.

- ▶ Tighten the screws on the bearing block and, if necessary, tighten the screws on the foot attachment.
Tightening torque (M16 8 and 8.8): 214 Nm

NOTE

The adjustment of the V-belt tension can be found in the *chapter "Readjusting the tension of the V-belts and quick-release bushings of the V-belt pulleys"* in the operating instructions.

- ▶ Screw the articulated shaft **(2)** to the vehicle's auxiliary drive flange **(1)** and to the V-belt pulley flange **(3)** of the compressor unit.
Tightening torque (M8 8.8): 25 Nm

3.8 Connecting the external oil cooler (optional)

NOTE

If the GHH RAND screw compressor or the compressor unit be operated under the conditions listed in *Chapter 1.14 on page 18*, a suitably selected oil cooler must be installed.

The oil cooler supply and return must be connected in accordance with the data given in *Chapter 1.7 on page 9* and *Chapter 3.6.4 on page 27*.

The erection of the cooler and the installation of the connection lines must be done so that when the screw compressor stops, the oil does not run back into the compressor.

The feed lines to the oil cooler must have the appropriate dimensions in order to ensure that there is sufficient pressure in the oil filter (minimum internal diameter of 10 mm).

The oil pressure gauge must be connected close to the compressor stage in the pipeline from the external oil cooler (*Chapter 1.7 on page 9*, connection R).

3.8.1 Installing the external oil cooler fan controller (optional)

The cooling of the compressor is handled by an external oil cooler, whose fan is switched on by the controller as soon as a particular oil pressure is reached in the compressor.

NOTE

The electrical connection must only be carried out by qualified personnel.

- ▶ Observe the mounting instructions of the respective vehicle manufacturer and local guidelines and specifications.

NOTE

Depending on the model, 1 or 2 electric fans can be connected to the controller. These are switched in parallel, so the connection sequence plays no role.

- ▶ Unscrew the cover **(2)** of the fan controller **(1)**.
- ▶ Pre-drill holder for the housing of the fan controller according to the fastening holes **(3)** (dimensions: 67 × 146 mm).
- ▶ Fasten the housing of the fan controller to the holder with four M4 screws.
- ▶ Screw the cover back onto the housing.
- ▶ Connect plugs **(A/B/C)** of the fan controller as follows:

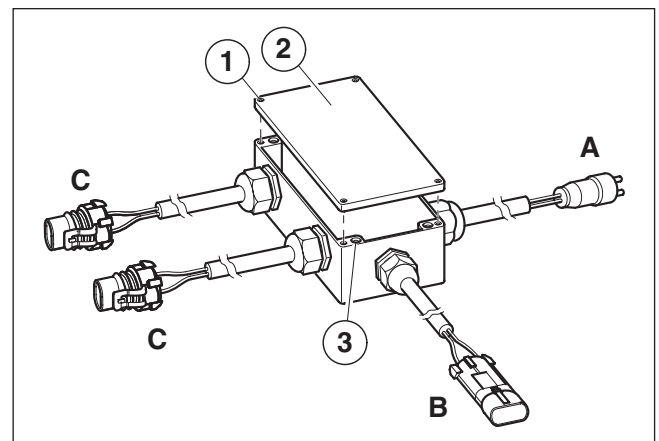

Plug	Identification/connection
A	OIL PRESSURE SWITCH: Oil pressure switch (<i>Chapter 3.6.4 on page 27</i>)
B	24 V DC: Vehicle power supply
C	FAN: Electric fan oil cooler

3.9 Connecting the control unit CG600 IC

- ▶ Attach the control unit for supplying power for the cooling fan to the connection option for 24 V DC provided by the vehicle manufacturer.

The connection must be fused with at least 20 A. The IC unit can either be connected to continuous or ignition voltage.

NOTE

The electrical connection must only be carried out by qualified personnel.

- ▶ Observe the mounting instructions of the respective vehicle manufacturer and local guidelines and specifications.

IC unit cable assignment:

Pos. pole (+): blue cable or marked with (1)

Neg. pole (-): brown cable or marked with (2)

NOTE

If the cooling fan is not running, check the cable for proper connection and polarity.

4 Safety labels

The safety labels must be attached by the installer of the system.

Apply maintenance instructions and lubricant recommendation (use the version in the local language of the operator)!

- ▶ Affix safety labels, maintenance instruction and lubricant recommendation to the relevant points of the installed compressor.
- ▶ Attach the second maintenance instruction where it can be clearly seen, e.g. in the driver's cab.
- ▶ Enter machine no. with waterproof pen.

NOTE

The areas that are to receive the stickers must be completely free of grease and dust!

- 1 Compressed air outlet/direction of flow
- 2 Hazardous electrical voltage (only for intercooler version)
- 3 Danger of burning! Hot surface
- 4 Do not enter
- 5 Read and follow the safety notes and operating instructions before starting operation
- 6 Wear hearing protection
- 7 Caution! No breathable air

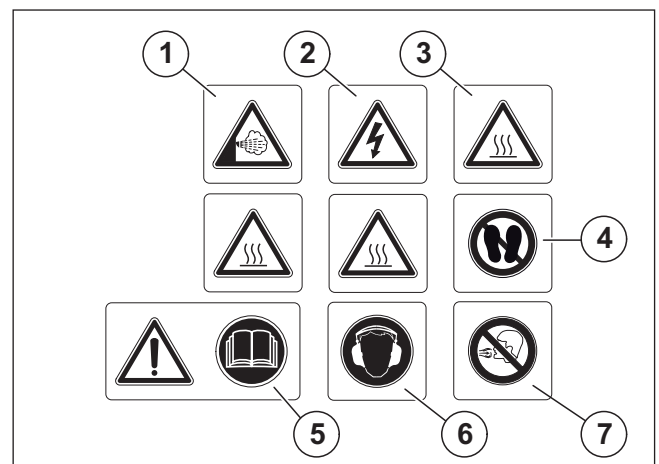

4.1 Attaching the stickers to the unit (example)

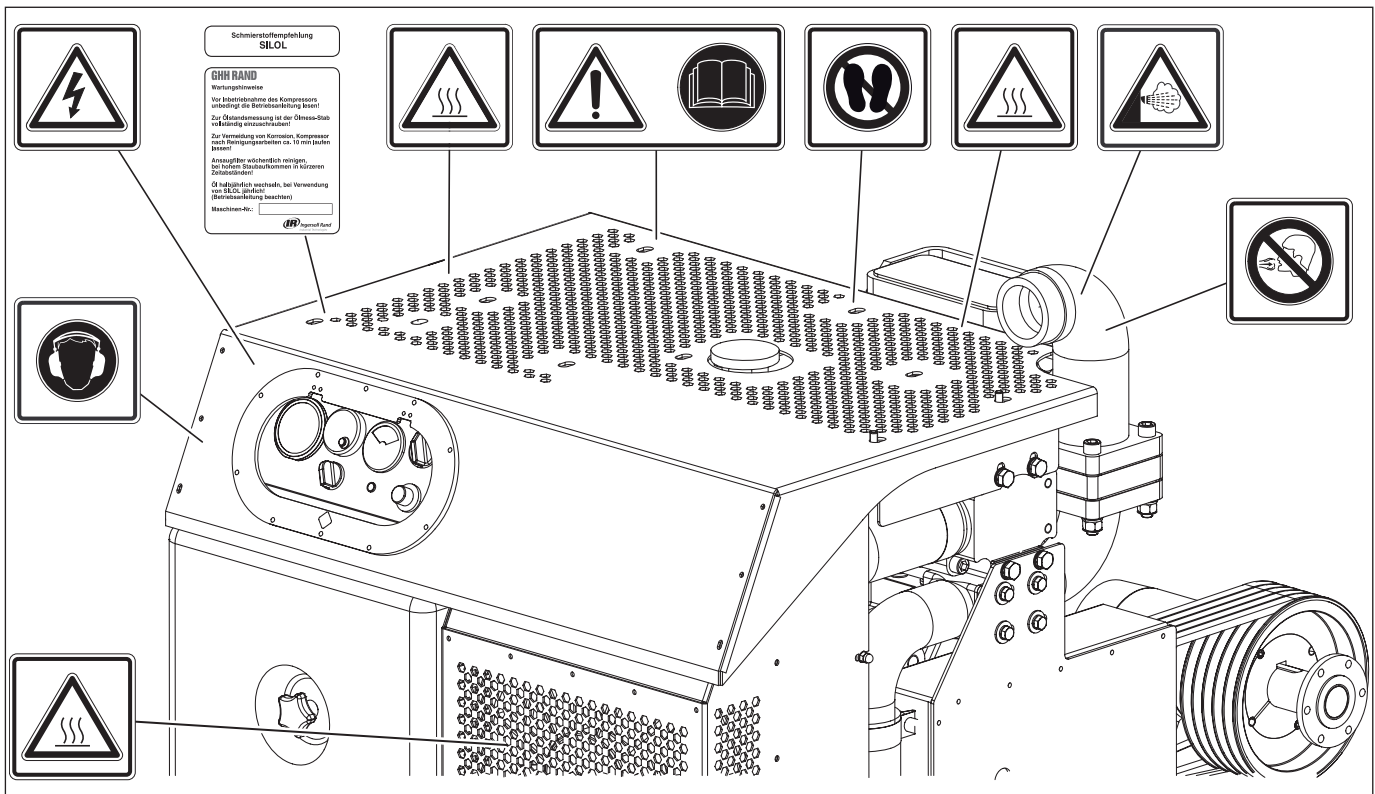

5 Initial commissioning

Initial commissioning is carried out by the installer of the system.

It includes filling with lubricant, removing the preservation, the test run with a check of the direction of rotation and speed, as well as the function control of the fan (IC unit).

If in exceptional cases the first start of operation is carried out by the customer, the following work has to be carried out:

Work	Section
Filling with lubricant	5.2
Removing the preservation	5.3
Test run	5.4
Switching On	5.4.1
Checking the direction of rotation	5.4.2
Checking the drive speed	5.4.3
Cooling fan	5.4.4
Switching off	5.4.6
Checks after the test run	5.4.7

5.1 Lubricant

We recommend using our fully synthetic high-performance lubricant, Silol.

If you use exclusively Silol or Silol FG (foodgrade) the interval for an oil change **doubles** to a max. **12 months**. The period of the manufacturer's warranty for new compressor units **is extended to 2 years**.

NOTE

For recognition of the guarantee extension, proof of the maintenance interval using Silol or Silol FG is required.

Depending on the operating conditions, brand-name motor oils with API classification SJ/CF as per SAE J183 can also be used.

The respective viscosity class (SAE class) can be taken from the following diagram.

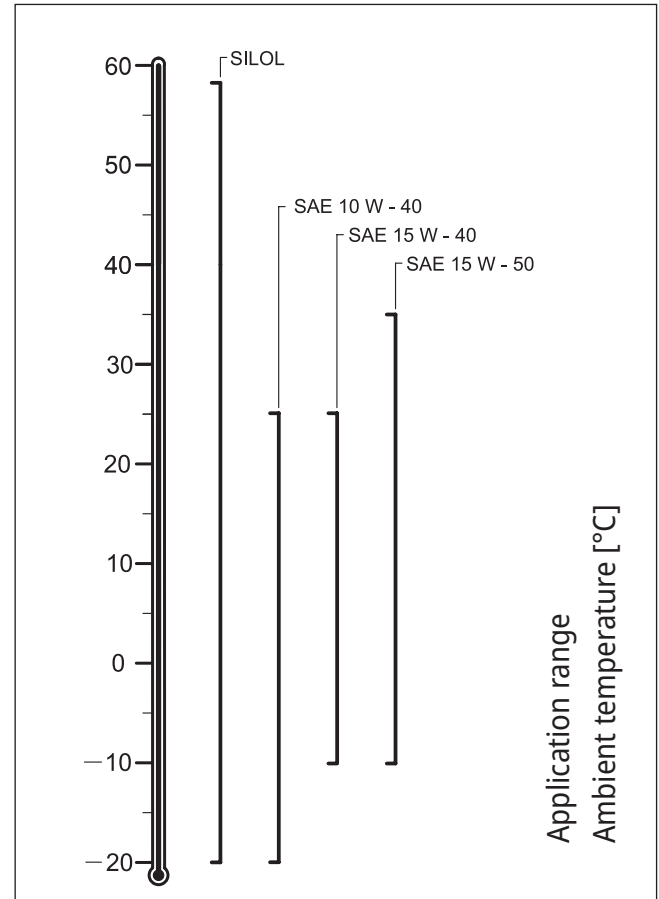

5.2 Filling with lubricant

NOTICE

DAMAGE DUE TO INCORRECT OILS!

Incorrect oils can destroy the compressor.

- ▶ Only use specified oil.

- ▶ Unscrew the oil dipstick **(1)**.
- ▶ Top up with new oil according to the lubricant recommendation (*Chapter 5.1 on page 41*):
CG80/CG600: approx. 9 litres
- ▶ Clean the oil dipstick **(1)** with a lint-free cloth and screw it in fully.
- ▶ Unscrew the oil dipstick **(1)** again.
The oil level must be between the min. and max. marks **(2)** on the oil dipstick. The difference between the min. and max. marks **(2)** approx. 1 litre.
Do not put in too much oil!
- ▶ Correct the oil level as needed.
- ▶ Screw the oil dipstick **(1)** back in.
- ▶ Make a note for the operator of the type of oil and the filling date.

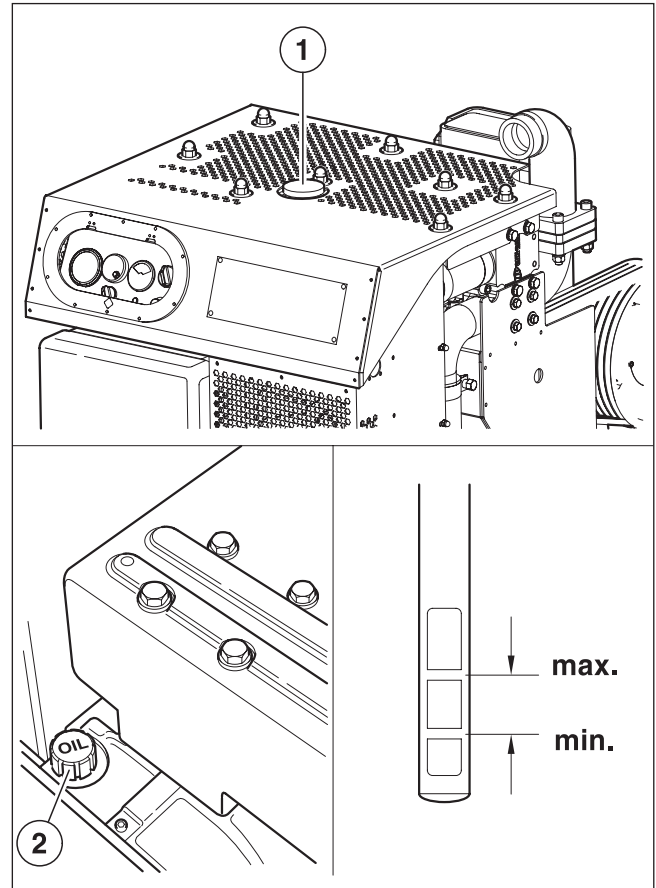

5.3 Removing the preservation

To prevent corrosion, the screw compressors are provided with an anti-corrosive agent.

During initial commissioning, the anti-corrosive agent evaporates and is blown off when the screw compressor warms up.

NOTE

Do not begin conveying until the screw compressor anti-corrosive agent has evaporated.

5.4 Test run

⚠ CAUTION

HOT SURFACES!

During operation, the compressor and discharge silencer are very hot. There is a risk of burning.

- ▶ Wear protective gloves.

⚠ CAUTION

NOISE GENERATION!

An excessive acoustic pressure level can result in damage to hearing.

- ▶ Do not operate the compressor without the discharge silencer.
- ▶ During operation, always wear suitable ear protection.

⚠ CAUTION

ROTATING PARTS!

Insufficiently covered parts can lead to injuries.

- ▶ During the checks, sufficient distance must always be kept from rotating parts.

The rotation direction, the rotational speed, the cooling fan (IC unit) and the flawless function of the safety equipment must be checked during the test run.

Preparation

- ▶ Make sure that the compressors are filled with oil in accordance with the recommendation for lubrication. Observe the fill quantity.
- ▶ Check all safety-relevant screw connections for firm seating.
- ▶ Check the V-belt tension before and after the test run and correct it if necessary.
- ▶ Before the test run, re-parameterise vehicle engines with EDC control.

5.4.1 Switching on

NOTICE

RISK OF BLOWBACK OF MATERIAL!

If the compressor is started if there is counter pressure, there is the risk of damage to the non-return valve due to blowback of material.

- ▶ Only start the compressor when completely depressurised.
- ▶ Never go into operation against a potentially existing counter pressure.

- ▶ Switch on power take-off.

5.4.2 Checking the direction of rotation

- ▶ Check the direction of rotation. When looking at the compressor drive shaft, the compressor must turn corresponding to the arrow marking on the compressor housing (clockwise, viewed looking towards the drive journal).

5.4.3 Checking the drive speed

NOTICE

INCORRECT SPEED RANGE!

An incorrect speed range can destroy the compressor.

- ▶ Ensure that the compressor is only operated within its permissible rotational speed range.

- ▶ Check the drive speed of the screw compressor.
The speed must remain within the speed range for the screw compressor specified in the technical data.

5.4.4 Cooling fan CG600 IC

Check the correct direction of rotation of the fan.

- ▶ The fan must convey the flow of air from the outside **(1)** to the inside.
- ▶ A sheet of paper held in front of the fan screen with a running fan must be sucked towards it.

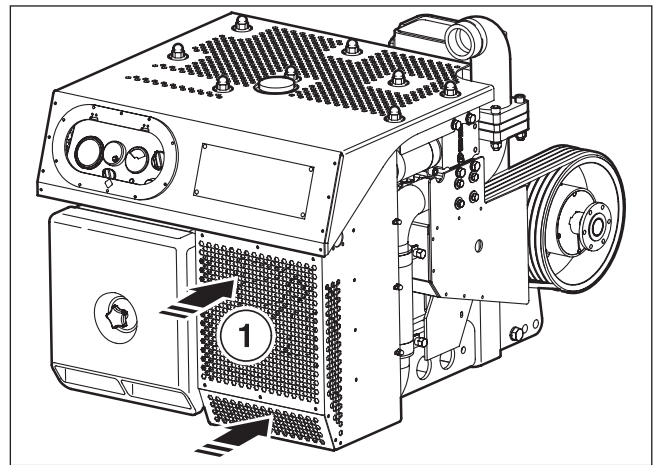

5.4.5 Function control of external oil cooler fan (optional)

A sheet of paper held in front of the radiator of a running fan must be sucked towards it.

NOTICE

DAMAGE TO THE COMPRESSOR!

The compressor can be damaged if the fan is defective.

- ▶ Check that the fan works.
 - The paper is sucked in by the fan.

5.4.6 Switching off

NOTICE

RISK OF BLOWBACK OF MATERIAL!

If the compressor is switched off if there is counter pressure, there is the risk of damage to the non-return valve due to blowback of material.

- ▶ Do not turn compressor off if there is counter pressure!
- ▶ If there is counter pressure, take appropriate measures to reduce pressure before switching off the compressor.

NOTE

The non-return valve installed in the compressor unit prevents the compressor from running backwards rapidly and for a long time (as a result of residual pressure in the compressed air lines of the pneumatic system) after being switched off.

In order to avoid an undesired blowback of material into the compressor, it is compulsory that at least one additional non-return flap be provided in the pneumatic system of the silo construction.

- ▶ Switch off power take-off.

5.4.7 Checks after the test run

- ▶ Check all screws including the quick-release bushings of the V-belt pulleys for firm seating, see chapter "*Readjusting the tension of the V-belts and quick-release bushings of the V-belt pulleys*" in the operating instructions.
- ▶ After the test run, check the oil level in the compressor and correct as required.

NOTICE**INSUFFICIENT LUBRICATION!**

Too low an oil level can damage the machine.

- ▶ After the test run, especially for compressors with an external oil cooler, the oil level in the compressor must be checked again and if necessary, the oil topped up, since otherwise the oil level sinks due to the filling of the oil cooler and the oil lines from/to the oil cooler in the test run.
- ▶ If necessary, carry out further short test runs and check the oil level repeatedly.

Printed in Germany

Reserves the right to amend technical details compared to the information and illustrations of the operating manual. A replication, copying or translation, even in parts, is not permitted without written consent.

As a contribution to environmental protection:

This paper has been produced from 100% chlorine free bleached pulp.

GHH RAND®

Service & Support

www.ingersollrand.com/ghhrandtransport



Subject to revision without notice

Printed in Fed. Rep. of Germany

12/2022 EN