

Mounting instructions

(Translation of the original instructions)

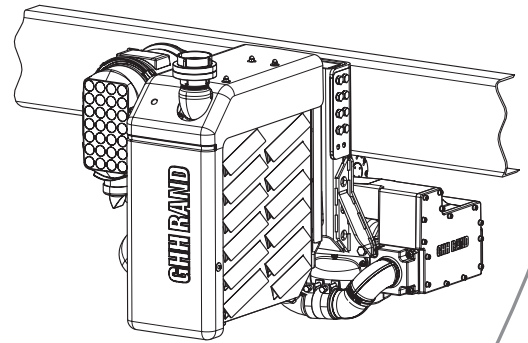
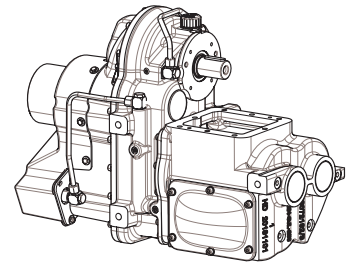
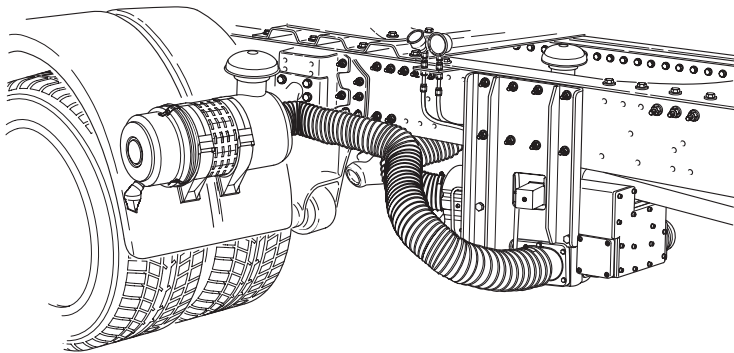

SILU CS104
SILU CS1200 LITE
SILU CS1200 ICL

DE WICHTIG!

Die Betriebsanleitung liegt in Ihrer Landessprache zusammen mit der Montageanleitung (englische und deutsche Ausführung) elektronisch auf der Webseite www.ingersoll.com/ghhrandtransport für den Download bereit. Auf Anfrage senden wir Ihnen auch gerne eine gedruckte Version zu.

EN IMPORTANT!

The operating instructions can be downloaded electronically in your language, together with the mounting instructions (in English and German) from the website www.ingersollrand.com/ghhrandtransport. On request, we will gladly send you a printed version.

CZ DŮLEŽITÉ!

Návod k provozu je k dispozici ke stažení v jazyce Vaší dané země společně s návodem pro montáž (anglická nebo německá verze) elektronicky na webové stránce www.ingersollrand.com/ghhrandtransport. Na vyžádání vám rádi zašleme i tištěnou verzi.

DK VIGTIGT!

Denne driftsvejledning på dit lands sprog ligger elektronisk og klar til download sammen med monteringsvejledningen (engelsk og tysk version) på hjemmesiden www.ingersollrand.com/ghhrandtransport. Efter forespørgsel sender vi dig også gerne en trykt version.

ES ¡IMPORTANTE!

El manual de instrucciones en su idioma junto a las instrucciones de montaje (en inglés y alemán) está disponible para su descarga en formato electrónico en www.ingersollrand.com/ghhrandtransport. Si lo desea, podemos enviarle también un ejemplar en papel.

FR IMPORTANT !

Vous pouvez télécharger la manuel d'utilisation dans la langue de votre pays avec les instructions de montage (en anglais et en allemand) au format électronique sur le site Web www.ingersollrand.com/ghhrandtransport. Sur demande, nous vous enverrons volontiers une version imprimée.

IT IMPORTANTE!

Le istruzioni d'esercizio sono disponibili in formato elettronico per il download sul sito www.ingersollrand.com/ghhrandtransport in lingua italiana, insieme alle istruzioni per il montaggio (edizione in inglese e in tedesco). Su richiesta saremo lieti di inviarvene anche una copia in formato cartaceo.

NL BELANGRIJK!

De gebruikshandleiding kan samen met de montagehandleiding (Engelse en Duitse versie) in uw taal elektronisch worden gedownload van de website www.ingersollrand.com/ghhrandtransport. Op aanvraag sturen we u met alle plezier ook een gedrukte versie.

PL WAŻNE!

Instrukcja obsługi dostępna jest w ojczystym języku użytkownika wraz z instrukcją montażu (w języku angielskim i niemieckim) w elektronicznej formie do pobrania na stronie internetowej www.ingersollrand.com/ghhrandtransport. Na życzenie chętnie prześlemy Państwu również wersję drukowaną.

SE VIKTIGT!

Bruksanvisningen går att hämta elektroniskt på landets språk tillsammans med monteringsanvisningen (på engelska och tyska) på webbsajten www.ingersollrand.com/ghhrandtransport. På begäran skickar vi även gärna ett tryckt exemplar.

FI TÄRKEÄÄ!

Suomenkielisen käyttöohjeen ja (englannin- ja saksankielisen) asennusohjeen voi ladata sähköisessä muodossa osoitteesta www.ingersollrand.com/ghhrandtransport. Pyydettyessä lähetämme myös tulostetun version.

BY ВАЖНА!

Электронную версию кіраўніцтва па эксплуатацыі на нацыянальнай мове разам з інструкцыяй па мантажы (на англійскай і нямецкай мовах) можна спампаваць на сайце www.ingersollrand.com/ghhrandtransport. Па асобным запыце мы з задавальненнем дашлем вам друкаваную версію.

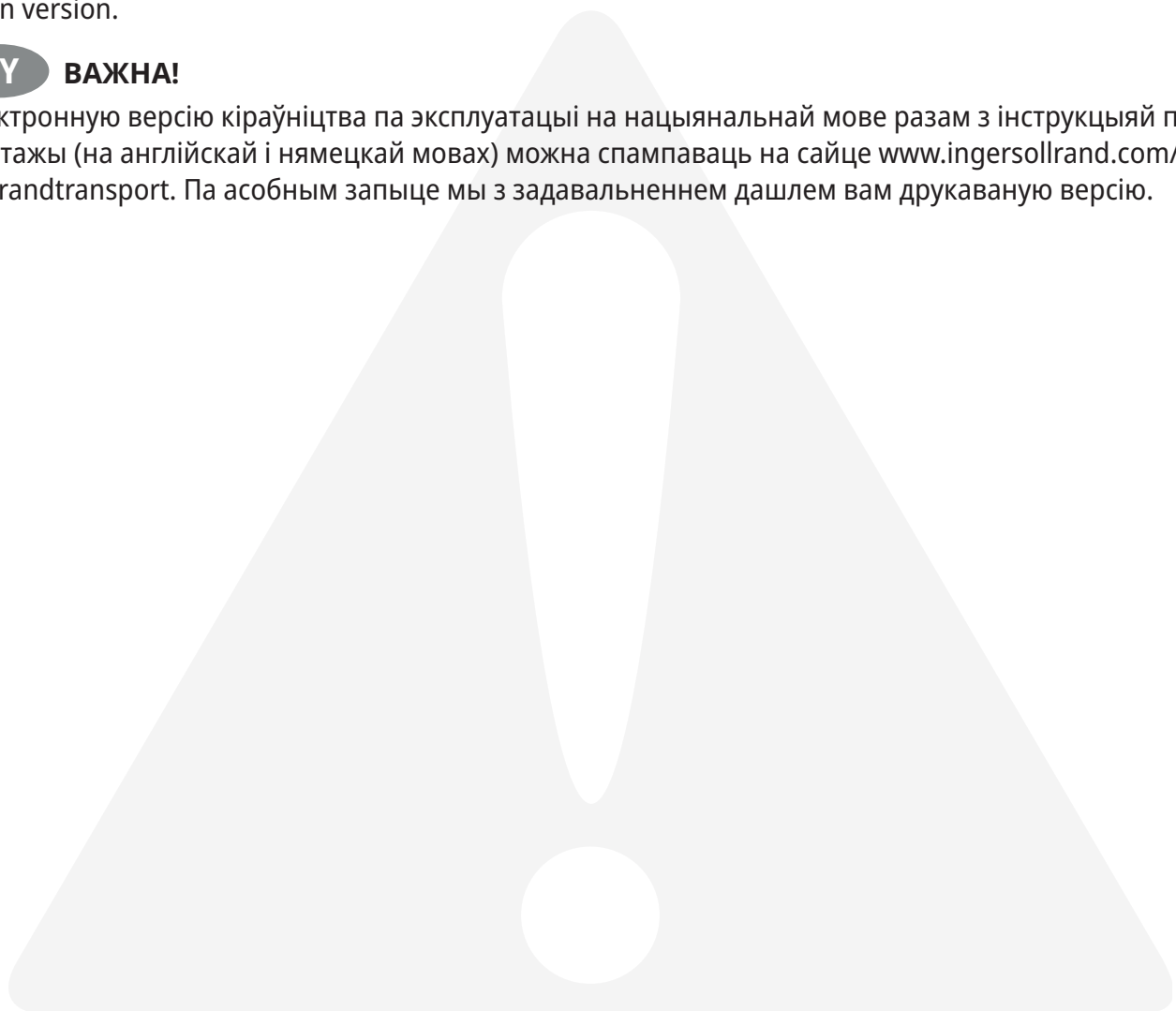

Introduction

Before installing and commissioning the SILU CS104 screw compressor, the SILU CS1200 LITE compressor kit or the SILU CS1200 ICL compressor unit, please read through these mounting instructions carefully (the additional designation SILU is not used in the rest of these mounting instructions).

The mounting instructions describe how to erect and commission the above-mentioned compressors.

Make sure that these mounting instructions are available to the installation personnel and that the tasks are carried out in accordance with the instructions contained in it.

Scope of application of the mounting instructions

The mounting instructions only contain instructions for mounting the above-mentioned screw compressor, the above-mentioned compressor kit and the above-mentioned screw compressor unit. The mounting instructions do not apply for the installation of components/units from other companies by an external installer. If a third-party manufacturer designs and manufactures a compressor unit based on the CS104 compressor stage, they are obliged to provide the end user with their own operating instructions.

Target group

The mounting instructions are restricted exclusively for use by qualified specialists.

Notes and safety instructions

The following instructions and safety notices are used in the mounting instructions to warn of dangers which could result in operating errors, injuries and tangible damage:

DANGER

DANGER warns of an imminent danger and indicates an imminent danger. This safety note warns of possible irreversible to fatal injuries.

WARNING

WARNING indicates a possible imminent danger. This safety note warns of serious or perilous injuries.

CAUTION

CAUTION indicates a possible imminent danger. This safety note warns of light injuries.

NOTICE

ATTENTION warns of possible tangible damage or malfunctions.

NOTE

NOTES contain instructions to prevent operating errors and other specific useful or important information.

Contents

1	GENERAL	7
1.1	Application	7
1.2	Manufacturer's address	7
1.3	Screw compressor type plate	7
1.4	Compressor unit type plate.....	8
1.5	Information for enquiries and orders	8
1.6	Service & Support	8
1.7	Technical data CS104 screw compressor.....	9
1.7.1	Performance data CS104 screw compressor	10
1.8	Technical data CS1200 LITE compressor kit	12
1.9	Technical data CS1200 ICL compressor unit	12
1.10	Technical data compressor unit.....	13
1.11	Operating the compressor at high altitudes.....	14
1.12	Maximum running time	14
1.13	External oil cooler for extreme conditions.....	15
2	SAFETY	16
2.1	General.....	16
2.2	Authorised personnel, training and qualification.....	16
2.3	Safety-conscious work.....	16
2.4	Safety instructions for the owner/operator	16
2.5	Unauthorised conversions and spare parts.....	17
2.6	Incorrect operating methods.....	17
2.7	Disposal.....	17
3	INSTALLATION GUIDELINES	18
3.1	Internal transportation	18
3.1.1	Internal transportation of the screw compressor	18
3.1.2	Internal transportation of the unit	19
3.2	Drive	19
3.2.1	Hydraulic actuation	19
3.2.2	Articulated shaft	20
3.3	Installation and position	20
3.3.1	Permitted inclination	21
3.4	Preparing installation.....	21
3.4.1	Required space conditions for the compressor kit and compressor unit	21
3.4.2	Checking the direction of rotation.....	21
3.4.3	Aligning the compressor on the vehicle/flange parallelism	21
3.4.4	Air flow CS1200 ICL/filter installation location CS1200 LITE	22
3.4.5	Air intake oil cooler fan CS104 L1/R1 compressor.....	23
3.5	Observe the tightening torques	23
3.6	Completion of the screw compressor.....	24
3.6.1	Installation of the hose connector flange	24
3.6.2	Mounting the maintenance indicator and oil pressure gauge	25
3.6.3	Oil cooler connection CS104 L2/R2 compressor	26
3.6.4	Mounting the air intake filter.....	26
3.6.5	Mounting the discharge silencer	27
3.6.6	Installing the safety valve	30

3.6.7	Mounting the non-return flap.....	31
3.6.8	Installing the overload coupling.....	31
3.6.9	Installing the screw compressor on the mounting console (third-party manufacturer)	33
3.6.10	Installing the pressure line	33
3.7	Completion of the compressor unit.....	34
3.7.1	Test mounting of the CS1200 LITE compressor kit	34
3.7.2	Test mounting of the CS1200 ICL compressor unit	37
3.7.3	Mounting of the CS1200 LITE compressor kit.....	39
3.7.4	Mounting of the CS1200 ICL compressor unit.....	42
3.7.5	Installing the articulated shaft.....	44
3.8	Connecting the external oil cooler to the CS104 L2/R2 compressor	44
3.8.1	Installing the external oil cooler fan controller (optional)	44
3.9	Connecting the control unit to the CS1200 ICL compressor unit	45
4	SAFETY LABELS	46
4.1	Attaching the stickers to the unit (example).....	47
5	INITIAL COMMISSIONING	48
5.1	Lubricant	48
5.2	Filling with lubricant.....	49
5.3	Removing the preservation.....	49
5.4	Test run.....	50
5.4.1	Switching on	50
5.4.2	Checking the direction of rotation.....	50
5.4.3	Checking the drive speed.....	51
5.4.4	Cooling fan CS1200 ICL	51
5.4.5	Function control of external oil cooler fan (CS104 L2/R2 compressor).....	51
5.4.6	Switching off	52
5.4.7	Checks after the test run	52

1 General

1.1 Application

GHH RAND builds and supplies the CS104 screw compressor and the CS1200 compressor units for installation on silo vehicles for the connection-ready unit.

Because of their oil-free compression of atmospheric air and their power-to-weight ratio for installation on silo vehicles, the compressor unit is used to pneumatically convey bulk goods, such as flour, sugar, salt, animal feed, powdered chemicals, dry granulate, soda, cement, sand, lime, plaster, etc.

The products built and supplied by GHH RAND are only designed for the operation at and on utility vehicles that exclusively drive on paved roads.

A different use requires consultation with the manufacturer.

1.2 Manufacturer's address

GHH RAND
Schraubenkompressoren GmbH
Max-Planck-Ring 27
46049 Oberhausen

1.3 Screw compressor type plate

The type plate is attached to the side of the screw compressor. It contains the following information:

- Type
- Serial no.
- Speed range
- max. volume flow
- At max. operating pressure
- max. power consumption

NOTE

The complete identification has certificate value and may not be changed or rendered illegible.

1.4 Compressor unit type plate

The type plate on the compressor unit is attached to the mounting console.

It contains the following information:

- Type
- Year of manufacture
- Compressor serial no.
- Unit serial no.
- Unit drive speed
- Intake volume
- max. operating pressure

NOTE

The type plate for the compressor kit supplied by GHH RAND must be created by the installation manufacturer and attached to the fully mounted compressor unit in a clearly visible place. It should contain the information listed above.

NOTE

The complete identification has certificate value and may not be changed or rendered illegible.

1.5 Information for enquiries and orders

If you have enquiries or orders for spare parts and accessories, please provide details of the exact type designation and the serial number of the screw compressor or the compressor unit, for which the spare part or accessory is intended.

CAUTION

USE OF UNAUTHORISED SPARE PARTS AND ACCESSORIES!

Original replacement parts and accessories that are authorised by the manufacturer represent safety factors. The use of non-original or non-authorised replacement parts and accessories may void the liability for the resulting consequences.

- ▶ Only use original spare parts and accessories authorised and approved by the manufacturer.

1.6 Service & Support

www.ingersollrand.com/ghhrandtransport

1.7 Technical data CS104 screw compressor

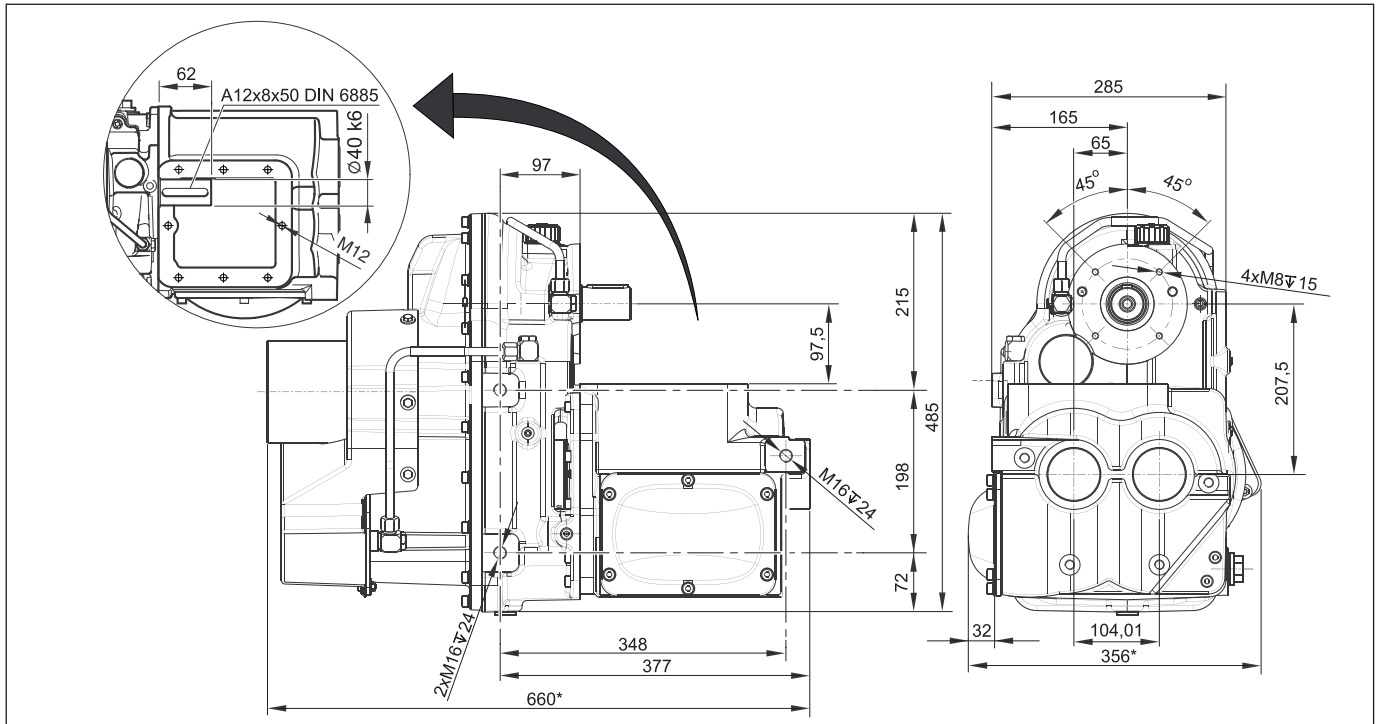

Model: CS104 **L1/R1** (version with integrated oil cooler for PTO R/L operation). All dimensions are approximate.
 *Dimension for model CS104 **L2/R2** (not depicted separately, other dimensions are identical)

Dimensions & weight		L1/R1	L2/R2	Rotational speed range	
Length (approx)	mm	660	535*	min. rpm	1200
Width (approx.)	mm	356	338*	max. rpm	1800
Height (approx)	mm	485	485		
Weight (approx)	kg	144/140	137/134		

Maximum operating pressure

max. 2.5 bar

Oil filling quantity

approx. 3 litres

Maximum intake negative pressure

max. 65 mbar

Minimum oil pressure

min. 0.3 bar

NOTE

Due to the various ways of regarding the direction of rotation of the drive, it must be ensured that the compressor stage with the following name is used:

CS1200 LITE/ICL for
 PTO-L with CS104 **Rx**
 PTO-R with CS104 **Lx**

Code key type designation

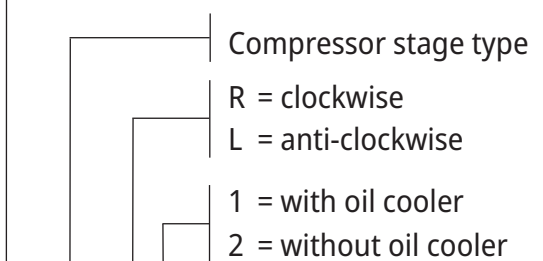

CS104 R 1

1.7.1 Performance data CS104 screw compressor

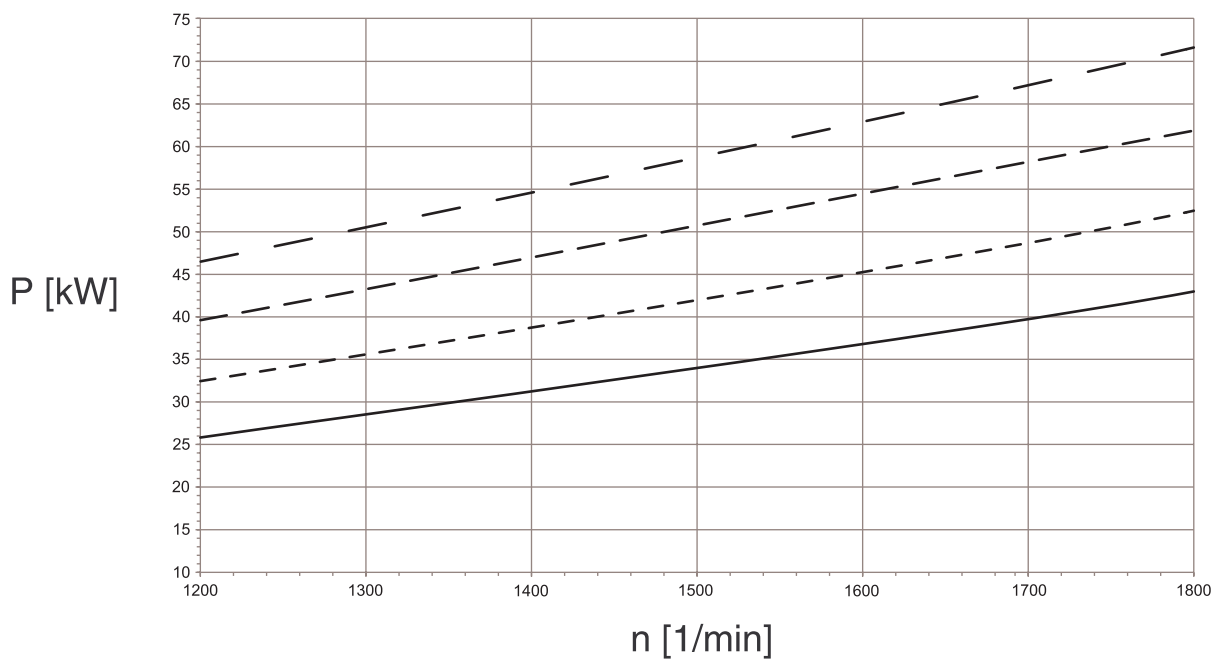
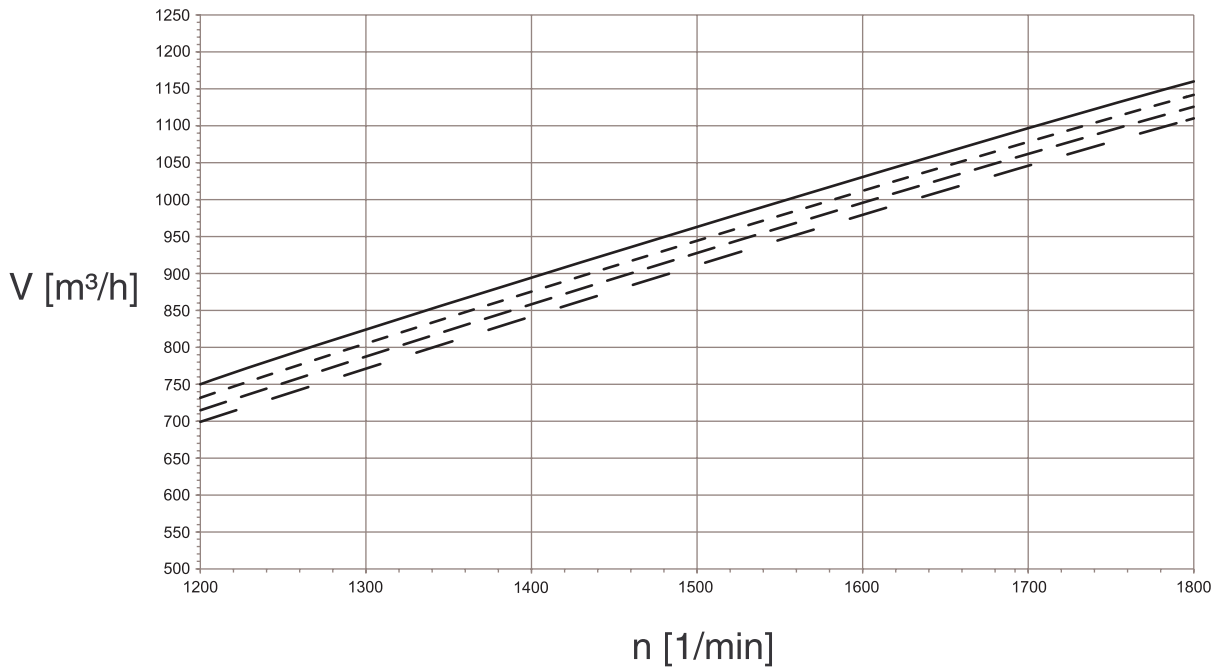

All information for:

Feed medium: atmospheric air
 Intake pressure: 1 bar (abs.)
 Intake temperature: 20 °C
 Permitted min. ambient temp.: -25 °C
 Relative humidity: 60 %
 Technical data without intake or pressure losses

n Drive speed
 V Intake volume
 t_2 Final temperature
 P Coupling output
 $t_{1,max}$ Permitted intake temperature

Pressure difference:
 — 1.0 bar
 - - - 1.5 bar
 - · - · 2.0 bar
 - - - - 2.5 bar
 ≤ 2.0 bar

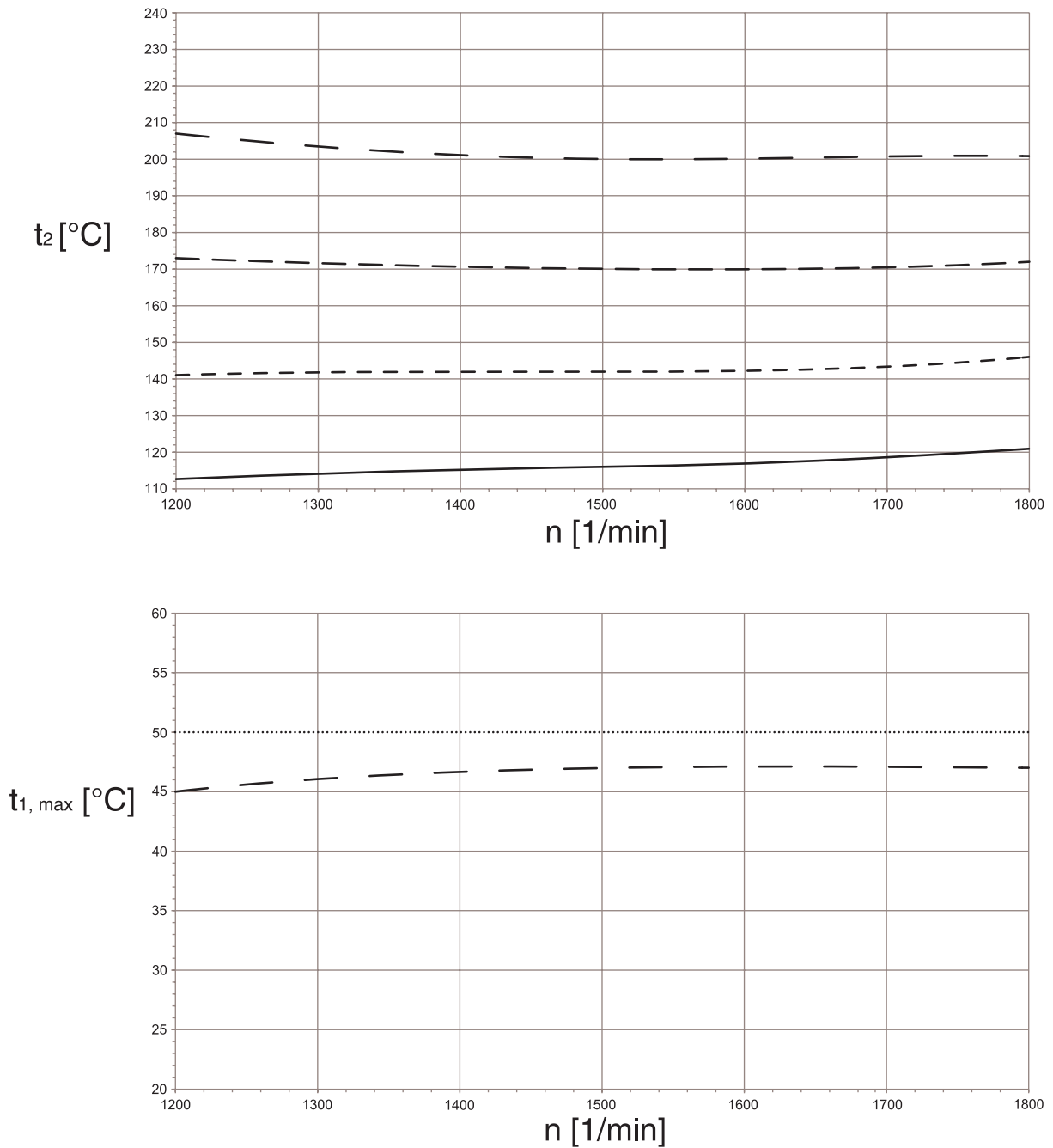

All information for:

Feed medium: atmospheric air
 Intake pressure: 1 bar (abs.)
 Intake temperature: 20 °C
 Permitted min. ambient temp.: -25 °C
 Relative humidity: 60 %
 Technical data without intake or pressure losses

n Drive speed
 V Intake volume
 t_2 Final temperature
 P Coupling output
 $t_{1,max}$ Permitted intake temperature

Pressure difference:

———— 1.0 bar
 - - - - - 1.5 bar
 - · - · - 2.0 bar
 - - - - - 2.5 bar
 ········ ≤ 2.0 bar

1.8 Technical data CS1200 LITE compressor kit

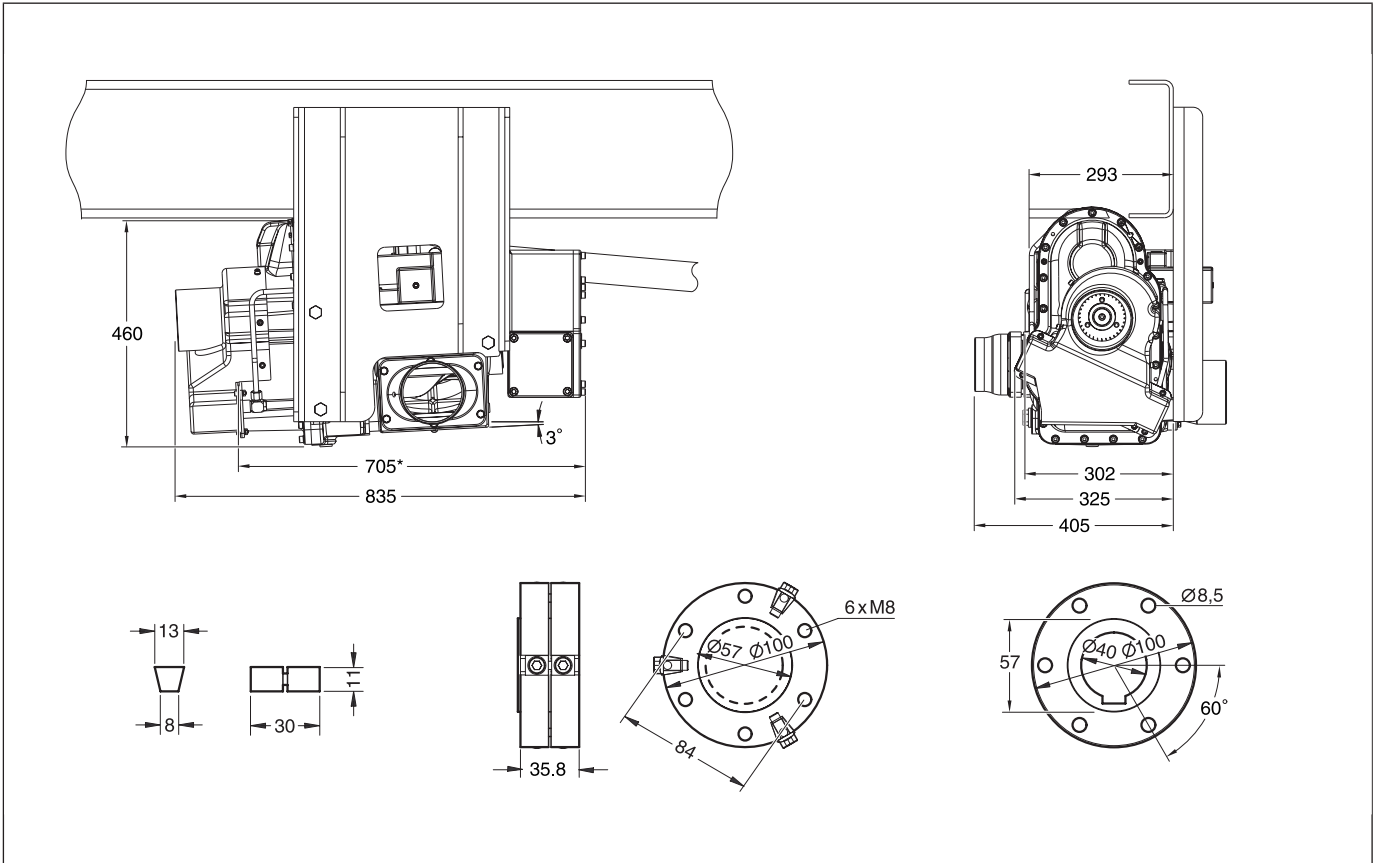

Model: CS1200 LITE with integrated oil cooler PTO R/L

All dimensions are approximate.

1.9 Technical data CS1200 ICL compressor unit

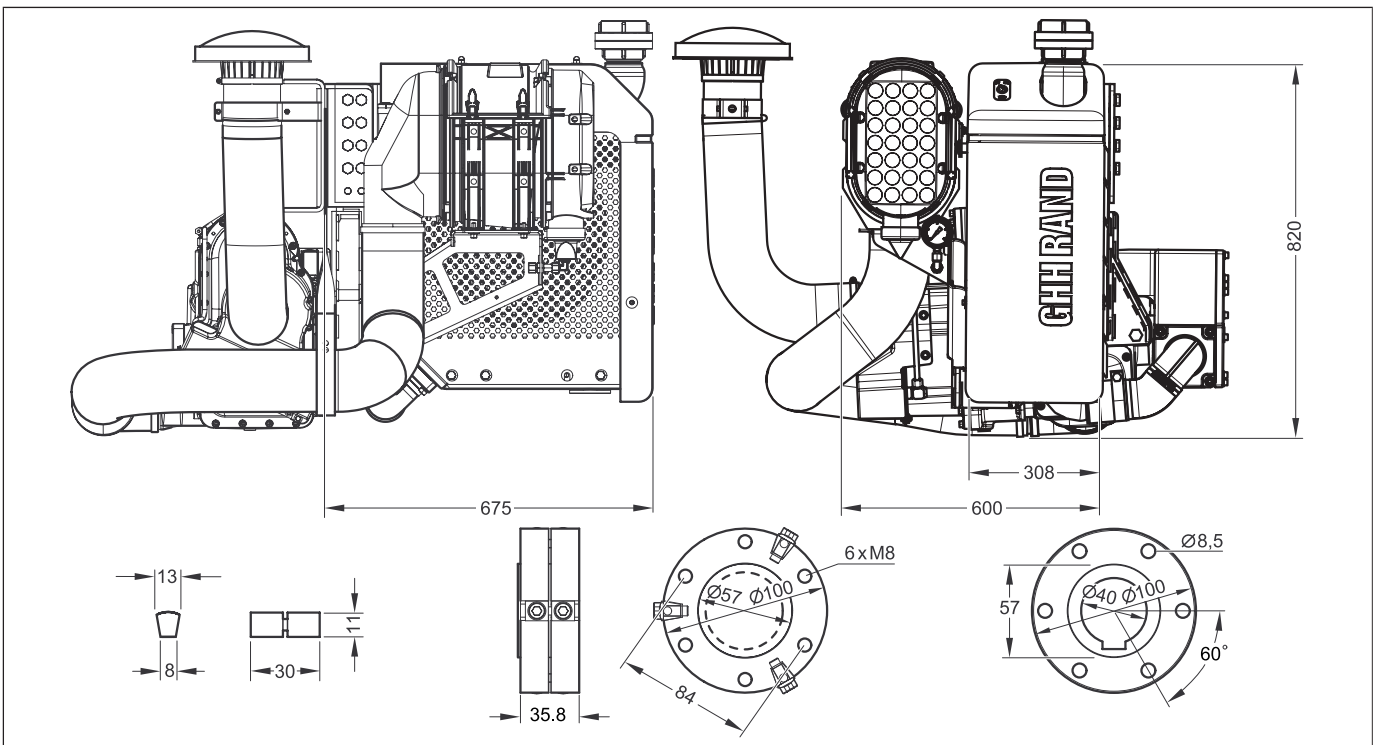

Model: CS1200 ICL with integrated oil cooler PTO R/L

All dimensions are approximate.

1.10 Technical data compressor unit

Dimensions & weight		CS1200 LITE	CS1200 ICL	Rotational speed range	
Length (approx)	mm	835/705*	865	min. rpm	1200
Width (approx.)	mm	405**	725	max. rpm	1800
Height (approx)	mm	460***	910		
Weight (approx)	kg	220	290		

* L2/R2 version without integrated oil cooler

** The space requirement may be larger with the use of spacers

*** Dimension up to lower edge of vehicle frame

NOTICE

DAMAGE TO THE COMPRESSOR!

Exceeding the permitted speed range leads to material damage.

▶ Do not operate the compressor outside of its permitted speed range.

Maximum operating pressure

max. 2.5 bar

Oil filling quantity

approx. 3 litres

Maximum intake negative pressure

max. 65 mbar

Minimum oil pressure

min. 0.3 bar

Connection dimensions

Pressure joint

R 2.5" external thread

Suction nozzle for intake air

Ø130 mm

Air intake fitting, oil cooler fan

Ø125 mm

Articulated shaft

Only articulated shafts with two joints are permitted.
Only balanced articulated shafts with a balance quality level of G 6.3 in accordance with DIN ISO 1940 with length compensation may be used.

NOTE

The performance data of the CS1200 LITE compressor kit and the CS1200 ICL compressor unit correspond to the CS104 screw compressor (*Chapter 1.7.1 on page 10*).

NOTE

More detailed information can be found in the separately available installation drawing of the compressor unit.

1.11 Operating the compressor at high altitudes

If operating the compressor at high altitudes, make sure that, depending on the existing ambient pressure, the operating overpressure must be reduced in order to prevent temperature damage to the compressor and compressor unit.

This should be carried out in accordance with the following table:

Installation height h [m]	0	1000	1500	2000	2500	3000	3500	4000	4500
Permitted operating overpressure $p_{\text{permitted}}$ [bar]	2.53	2.25	2.11	1.99	1.87	1.75	1.64	1.54	1.44

NOTICE

TEMPERATURE DAMAGE!

An ambient temperature outside the permitted range can result in damage to the compressor.

- ▶ The existing ambient temperature and intake temperature must be in the range of -20°C to $t_{1,\text{max}}$ (for pressure difference 2.5 bar, refer to respective type of compressor) (*Chapter 1.7.1 on page 10*).

1.12 Maximum running time

The maximum permitted running time is 3 hours. Subsequently, there must be a minimum pause of 1 hour. Non-adherence to the running time can result in damage caused by overheating.

NOTE

Due to their construction, the screw compressor and the compressor unit are designed for the intermittent operation as described above. Continuous use of the compressor leads to a reduced service life. The use of an external oil cooler can improve the service life in the case of extended runtimes and extreme conditions.

1.13 External oil cooler for extreme conditions

To give the compressor an optimum service life, an external oil cooler* must be operated under the following conditions:

a) When operating in an enclosed environment (encapsulated), e.g. customer-owned or direct-driven systems with a cover/casing, or our own electrical/diesel systems

or

b) When operating in challenging/cramped environments, e.g. installations in the immediate vicinity of other systems/installations on the vehicle frame that are subject to heat development and/or that prevent an unimpeded supply of fresh air (e.g. vehicle exhaust systems, side plates, cladding, etc.)

or

c) For operating times that exceed the typical duration of use of standard silos (up to 5 discharges per day; typical discharge times of up to 3 hours)

or

d) When the breaks in operation between discharges are less than 1 hour

NOTE

In order to uphold any warranty claims, maintain the highest product reliability and service life in terms of the compressor stage and lubricant, an external oil cooler must be installed and used in the specified cases.

It must be ensured that it is correctly dimensioned depending on the prevailing environmental conditions.

* The required heat dissipation of the oil cooler should be at least 4 kW @ 10 litres of oil/min. and 30 °C ambient temperature (T1 or equivalent; while observing the installation specifications of the oil cooler). For special applications, for e.g. in the case of ambient temperatures above 35 °C, the oil cooler must accordingly be designed to be larger (T2 or equivalent, while observing the installation specifications of the oil cooler).

2 Safety

2.1 General

These mounting instructions contain fundamental instructions which must be adhered to when performing assembly and installation. This mounting instruction must therefore be read in full by the responsible specialist staff before starting work.

2.2 Authorised personnel, training and qualification

Installation and assembly work must only be carried out by persons with the appropriate authorisation, training and qualifications, who are familiar with the valid safety regulations.

Repairs or modifications must only be performed by authorised personnel who is available at any time at the service sites or at GHH RAND.

2.3 Safety-conscious work

The safety-related regulations that are relevant for the installation, operation and maintenance of air compressors can be found in the following publications:

Machinery Directive 2006/42/EC

Standards, in particular:

DIN EN ISO 12100-1/2	Safety of machinery
DIN EN 1012-1	Compressors and vacuum pumps, safety requirements

The regulations of the professional associations, in particular:

BGI 666	Sample operating instructions for operation of container vehicles for granular or dust-like goods (silo vehicles).
---------	--

In this context, the respectively last applicable versions of these regulations shall be authoritative. Special legal provisions and regulations, particularly safety regulations, that may apply in your company or due to local conditions must also be adhered to. In case of competing regulations, the more restrictive provisions shall be applied. You must also observe any national regulations in the respective country of use.

2.4 Safety instructions for the owner/operator

The owner/operator is responsible for ensuring that the screw compressor is in a safe operational condition. Damaged or faulty parts must be immediately replaced. If the screw compressor is used to convey combustible materials, make sure that the temperature remains below the spontaneous ignition temperature for any dust/air mixture which may be created. In accordance with the professional association regulation BGI 666, for the pneumatic transport of materials subject to dust explosion, a temperature limit of max. 120 °C must be adhered to (measurement point before contact with the materials to be conveyed).

2.5 Unauthorised conversions and spare parts

Conversions and modifications to the screw compressor and screw compressor unit are not permitted. In the event of damage to the lead seal, any warranty claims are invalid.

Original replacement parts and accessories that are authorised by the manufacturer represent safety factors. The use of non-original or unauthorised replacement and accessory parts may void the liability for resulting consequences.

2.6 Incorrect operating methods

WARNING

INCORRECT OPERATING METHODS!

The operation of the compressor under incorrect conditions may lead to serious injuries and significant material damage.

- ▶ The compressor must only be operated under permitted conditions.

Unless approval is obtained from GHH RAND, the compressor must only be operated under the conditions stated in *Chapter 1.7 on page 9* to *Chapter 1.13 on page 15*.

2.7 Disposal

Compressor components, as well as operating materials used in conjunction with the compressor, compressor kit and compressor unit must be disposed of observing the local regulations.

3 Installation guidelines

NOTE

Also observe the safety instructions in *Chapter 2 on page 16*.

3.1 Internal transportation

3.1.1 Internal transportation of the screw compressor

The screw compressor and the accessories are delivered separately.

The screw compressor is on a pallet and secured with straps.

The accessories are delivered in a separate box.

⚠ WARNING

RISK OF TIPPING OVER IF TRANSPORTED ON THE GROUND!

If using internal transport with insufficiently dimensioned transportation equipment, there is a risk of tipping over and injuries.

- For internal transportation, use a sufficiently dimensioned lifting truck or fork lift.

For the transport of the screw compressor with a crane, it is possible to screw a ring screw **(1)** into the threaded hole (M12) on the top of the compressor.

⚠ WARNING

RISK OF FALLING IF TRANSPORTED USING A CRANE!

Serious injuries, including death, are possible if the screw compressor falls when transporting using a crane.

- Use sufficiently dimensioned lifting accessories.

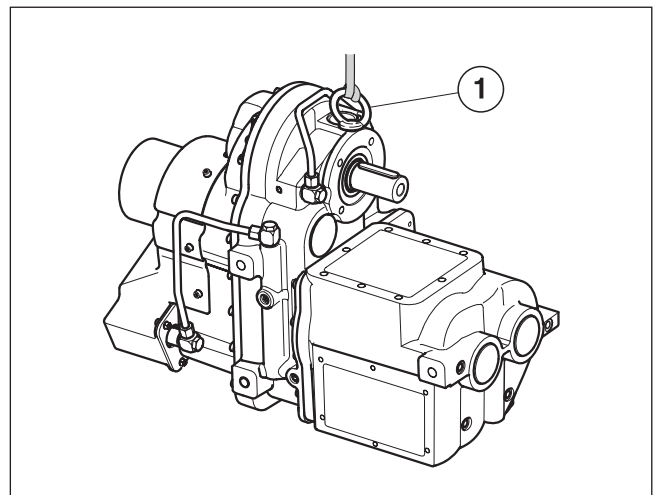

3.1.2 Internal transportation of the unit

The compressor unit (1) is fastened to a euro-pallet (2). For transportation, use a sufficiently dimensioned lifting truck/fork lift.

WARNING

RISK OF TIPPING OVER IF TRANSPORTED ON THE GROUND!

If using internal transport with insufficiently dimensioned transportation equipment, there is a risk of tipping over and injuries.

- ▶ For transportation, use a sufficiently dimensioned lifting truck or fork lift.

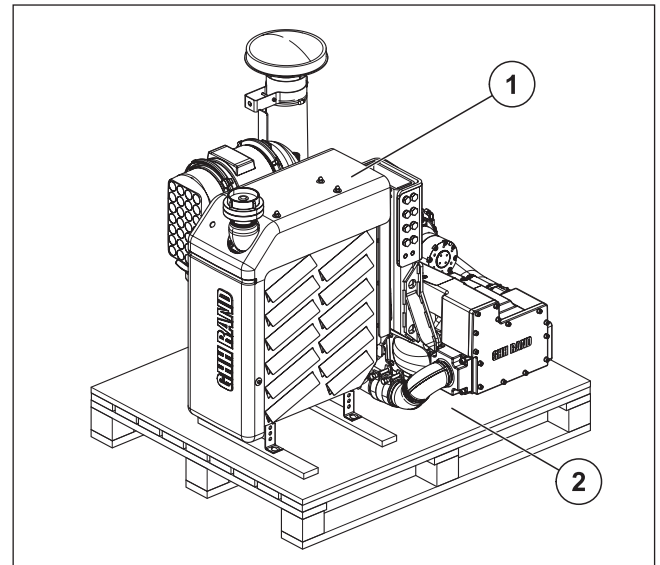

3.2 Drive

The compressor can be driven directly using an articulated shaft or using a hydraulic drive.

To protect the drive (vehicle drive), an overload coupling is included in the scope of delivery of the CS1200 LITE/ICL.

NOTICE

DAMAGE TO THE DRIVE!

Not installing an overload coupling can lead to damage to the drive.

- ▶ If no overload coupling is installed, other safety measures must be taken (e.g. articulated shaft catcher).

NOTICE

DAMAGE TO THE COMPRESSOR!

If the required operating speed is not reached promptly, the compressor can overheat and this leads to damage to the compressor.

- ▶ During operation, the operating speed must be reached promptly.

3.2.1 Hydraulic actuation

NOTE

For more information about the hydraulic drive of the compressor, please contact GHH RAND.

When operating a tilting bulk carrier vehicle, the hydraulic pump of the tilting plunger can also be used for the compressor drive.

3.2.2 Articulated shaft

The compressor drive is usually carried out through an articulated shaft between the power take-off of the vehicle drive and the flange of the overload coupling.

Selection of articulated shaft

Consider the following items during the determination of the articulated shaft:

- ▶ Determine the length of the articulated shaft considering the installation dimensions while paying attention to the maximum permitted expansion length.

NOTICE

DAMAGE TO THE COMPRESSOR DRIVE!

Incorrect installation of the articulated shaft can result in damage to the compressor drive.

- ▶ For the maximum permitted extension length of the articulated shaft, refer to the operating manual of the manufacturer of the articulated shaft and maintain during installation.

NOTE

The selection of the articulated shaft should only be made after the test mounting of the compressor on the vehicle (*Chapter 3.7.1 on page 34*), since this is how the precise installation location of the compressor is determined.

The overall inclination angle α of the articulated shaft must not exceed 12° .

In exceptional cases, where installation space is limited, larger angles of up to 15° may be permitted in consultation with the vehicle manufacturer using special articulated shafts.

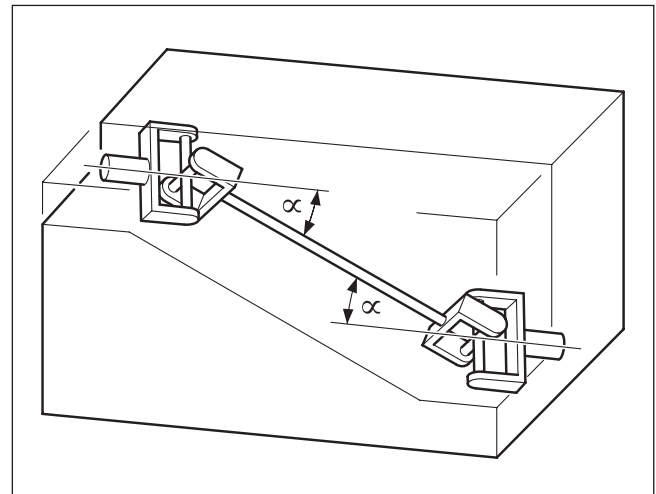

3.3 Installation and position

The compressor unit must be connected to the vehicle frame using a mounting console (retaining device). If a mounting console not supplied by GHH RAND is used, the dynamic load resulting from the weight of the compressor and attachment parts and the condition of the road must be taken into account when designing it.

In addition, observe the regulations and instructions from the respective vehicle manufacturer.

The screw compressor has an attachment on one side. It must be installed on a level, torsion-free base. It must be screwed to the console at all 3 attachment points provided (*Chapter 1.7 on page 9*).

3.3.1 Permitted inclination

NOTICE

INSUFFICIENT LUBRICATION!

Excessive inclination results in irregular level of lubricant in the housing.

- ▶ Observe the maximum permitted inclination of the screw compressor during operation:
 - To the front and to the rear: 10°
 - To the right and left: 10°

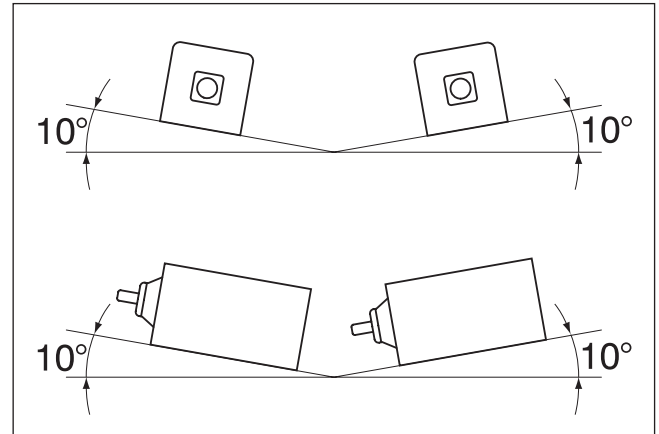

3.4 Preparing installation

The approximate position of the compressor and the compressor unit on the vehicle must be determined prior to the installation considering the following framework conditions.

Accessibility to the oil pressure gauge, negative pressure indicator, oil dipstick or oil inspection glass, oil drain plug or oil intake strainer must be taken into consideration during installation.

NOTE

The exact position of the compressor unit on the vehicle can only be determined in the course of a trial assembly after completing the compressor unit.

3.4.1 Required space conditions for the compressor kit and compressor unit

Check the space required on the truck on the right-hand side (in the direction of travel), taking into consideration the respective unit dimensions.

Dimensions of the line of products, see *Chapter 1.7 on page 9* to *Chapter 1.8 on page 12*.

3.4.2 Checking the direction of rotation

Check that the direction of rotation of the compressor model (as ordered) matches the direction of rotation of the vehicle engine's power take-off (viewed in the direction of travel):

If the power take-off rotates in anti-clockwise direction, install the **CS104 R** compressor unit.

If the power take-off rotates in clockwise direction, install the **CS104 L** compressor unit.

3.4.3 Aligning the compressor on the vehicle/flange parallelism

Installation and alignment of the compressor unit must be carried out so that the flange of the overload coupling installed on the compressor is aligned parallel to the articulated shaft flange of the power take-off.

NOTE

The mounting consoles of the CS1200 LITE compressor kit and the CS1200 ICL compressor unit are supplied with an inclination (per drill pattern) of 3° (*Chapter 1.8 on page 12*).

NOTICE**DAMAGE TO THE BEARING!**

Non-observance of attachment, flange parallelism and angle of inclination of the articulated shaft can result in significant bearing loads, with the result of premature damage to the bearing.

- Fundamentally, the structural guidelines from the manufacturer of the respective vehicle and technical information provided by the manufacturer of the articulated shaft with regard to attachment, flange parallelism and angle of inclination of the articulated shaft must be adhered to.

NOTE

To ensure flange parallelism, the compressor unit may have to be installed at a slight angle (side view) or any existing frame inclination, frame offset or auxiliary frame must be compensated for by using special adapters, shims or chocks.

Special adapters can be obtained from GHH RAND for various vehicle types and positions. For more information, please contact GHH RAND.

3.4.4 Air flow CS1200 ICL/filter installation location CS1200 LITE

The air flow for the cooling fan of the CS1200 ICL must be able to circulate freely and may not be affected by cover plates, etc.

The air intake fitting or the air filter of the CS1200 must not be in the area of the hot exhaust outlet. If necessary, move the vehicle engine's exhaust system or the installation location of the air filter (CS1200 LITE only).

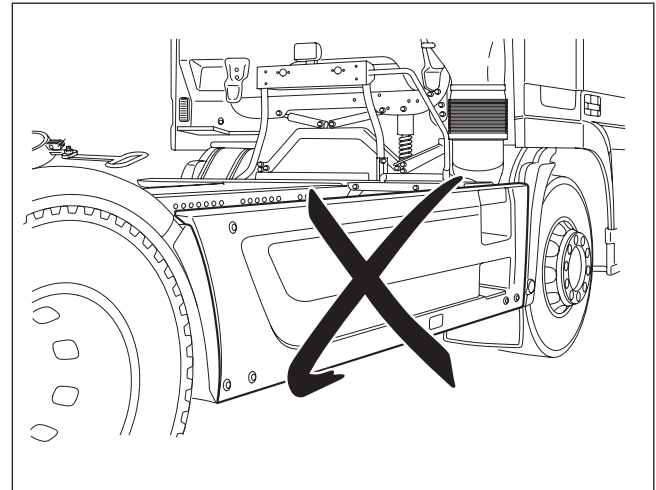
**NOTICE****INSUFFICIENT FRESH AIR SUPPLY!**

For vehicles with side cladding installed, the side cladding must be folded down or removed before switching on the compressor unit in order to prevent temperature damage to the compressor.

- Ensure sufficient fresh air supply.

NOTE

To prevent pressure losses, the nominal width (NW130) of the connection line for the air intake filter may not be reduced. The connection line should be kept as short as possible and installed in a straight line.

The connection of the air intake line to the compressor can be made using optionally-available intake fittings (straight or 40° angled) that have a hole for connecting the maintenance indicator.

NOTE

The compressor housing has two identical intake flanges on both sides, of which one is sealed with a cover. By exchanging the cover and intake fittings, the connection of the intake hose can also be made from the vehicle interior, see *Chapter 3.6.1 on page 24*.

3.4.5 Air intake oil cooler fan CS104 L1/R1 compressor

For compressors and units with an integrated oil cooler (compressor types CS104 L1/R1), the rain cap for the air intake of the oil cooler fan must be installed in the vehicle frame so that it is outside the spray areas and the cleanest, coldest possible air is sucked in.

NOTICE

INCORRECT INSTALLATION POSITION OF THE AIR INTAKE OIL COOLER FAN!

If the fresh air supply to the oil cooler fan is restricted, is located in the area of warm air or dirt gets into the oil cooler, temperature damage to the compressor could occur.

- ▶ Ensure sufficient fresh air supply.
- ▶ Do not operate the compressor without an air intake oil cooler fan.
- ▶ The air intake must not be located in the area of warm air (e.g. exhaust air from the engine).

NOTE

To ensure sufficient air throughput, the nominal width (NW 125) of the connection line for the oil cooler fan may not be reduced. The connection line should be kept as short as possible and installed in a straight line.

3.5 Observe the tightening torques

The tightening torques are specified in the following chapters.

WARNING

INCORRECT TIGHTENING TORQUE!

An incorrect tightening torque can endanger the secure attachment of the compressor, or result in damage to components due to excess tightening torques.

- ▶ The specified tightening torques must be observed.

3.6 Completion of the screw compressor

NOTICE

FOREIGN OBJECTS IN THE COMPRESSOR!

If foreign objects enter the screw compressor during completion, the screw compressor will be destroyed when it is started up.

- ▶ Make sure that no foreign objects enter the screw compressor.

3.6.1 Installation of the hose connector flange

NOTE

The intake flange can also be mounted on the opposite side instead of the cover; the free flange is then sealed by the cover.

- ▶ Remove protective film on the intake flange **(1)** of the compressor.
- ▶ Fasten the hose connection flange **(3)** with the seal **(2)** on the intake flange with screws **(5)** and **(7)** and plain washers **(4)**.
Initially tighten the screws only by hand, tightening one screw then tightening the screw opposite so that all are tightened evenly.

NOTE

The screws are only tightened when the installation location for the test mounting of the compressor on the vehicle (*Chapter 3.7.1 on page 34*) proves suitable.

The cover and intake flange can thus be changed if necessary without having to replace the seals.

When doing so, make sure that the fastening screws **(5)** and **(7)** are also replaced.

NOTE

For easy later mounting, pay attention to the position of the hole for connecting the maintenance indicator. Optionally, a 40° connection flange is also available.

- ▶ **Tightening torque (M8 8.8): 27 Nm**

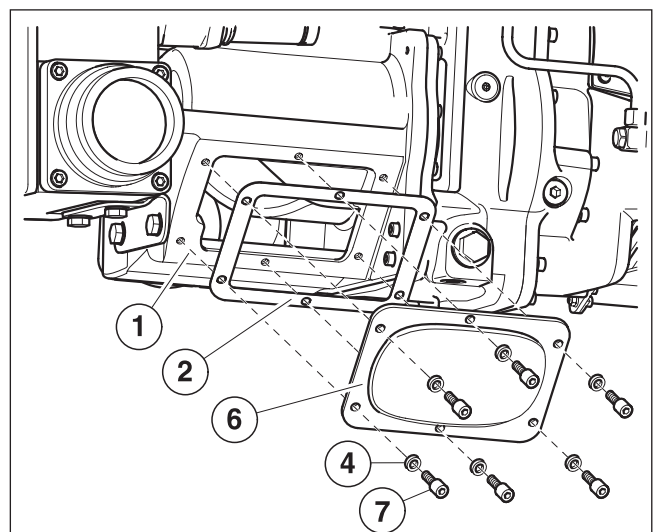
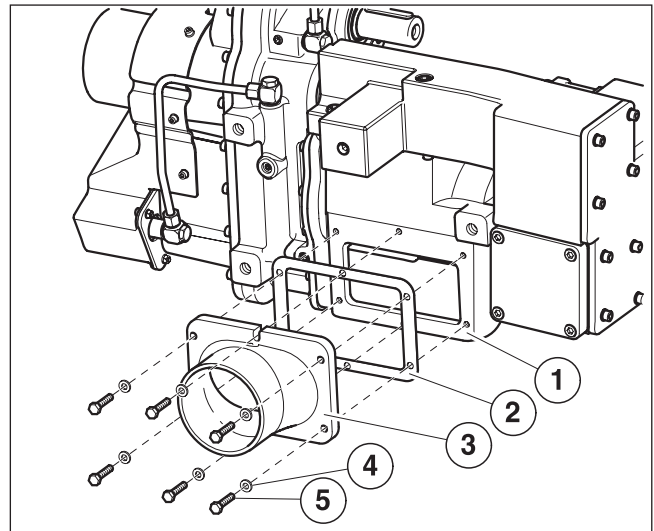

3.6.2 Mounting the maintenance indicator and oil pressure gauge

The screw connections for connecting the maintenance indicator and the oil pressure gauge should be attached before vehicle assembly.

Maintenance indicator:

- Screw the hose connection fittings (8) and (7) into the hole (5) on the air intake fittings (6).

NOTE

Depending on the position of the hole in the hose connection fitting (6), the pipe connector (7) can be screwed directly into the hose connection fitting, the bend (8) is not needed then.

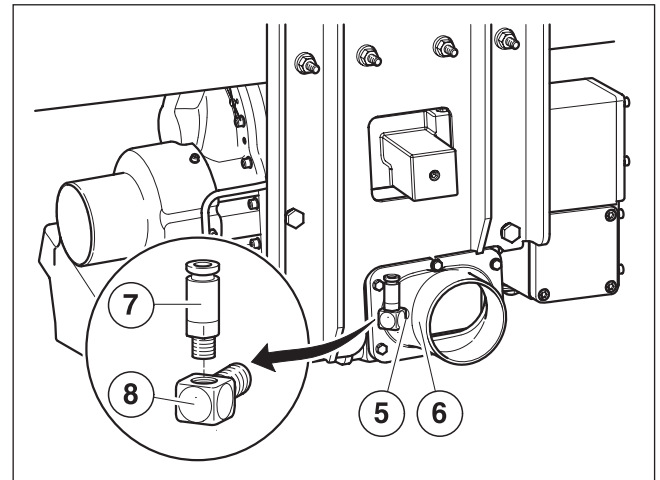

Oil pressure gauge:

- At one of the three possible connection points (1) for the oil pressure gauge, unscrew the hexagon socket screw (2) (M12×1.5) and screw in the elbow (3) or double nipple (4) to the connection of the line to the oil pressure gauge.

NOTE

Accessibility to the maintenance indicator and the oil pressure gauge must be taken into account during installation on the vehicle.

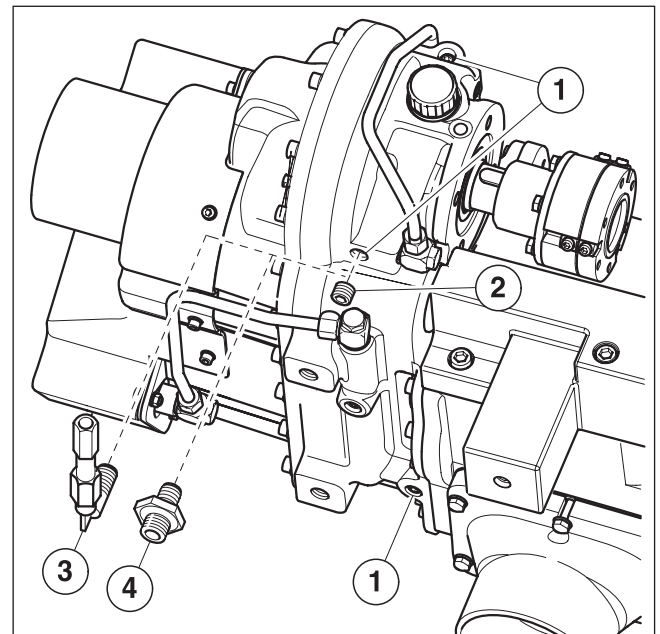

NOTICE

UNSUITABLE INSTALLATION TOOLS!

The maintenance indicator can become damaged if unsuitable tools are used during installation.

- Do not use pliers or lever tools to install the maintenance indicator.

NOTICE

HIGH OPERATING TEMPERATURES!

The oil pressure gauge and maintenance indicator could be damaged if they are exposed to ambient temperatures greater than 60 °C.

- ▶ Do not mount the oil pressure gauge and maintenance indicator in the immediate area of hot parts or in the exhaust area of the safety valve.
- ▶ When installing, make sure that there is a minimum distance of 5 cm between it and the discharge silencer and other hot components.

3.6.3 Oil cooler connection CS104 L2/R2 compressor

The screw connections for connecting the oil lines to the oil cooler should be attached before vehicle assembly. The position and size of the connections are as indicated:

- ▶ **(1)** Threaded hole (M14x1.5) depth (d) = 15 mm for connection line to the oil cooler (flow).
- ▶ **(2)** Threaded hole (M14x1.5) depth (d) = 15 mm for connection line from the oil cooler (return).

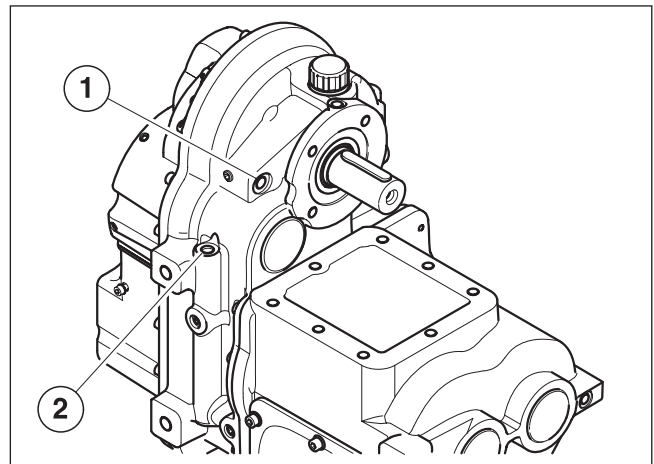

- ▶ The external oil cooler is operated via the fan controller (*Chapter 3.8.1 on page 44*) and the required oil pressure switch **(6)**. The oil pressure switch **(6)** must be integrated in the pipeline to the external oil cooler **(1)** using a suitable screw connection **(5)**.

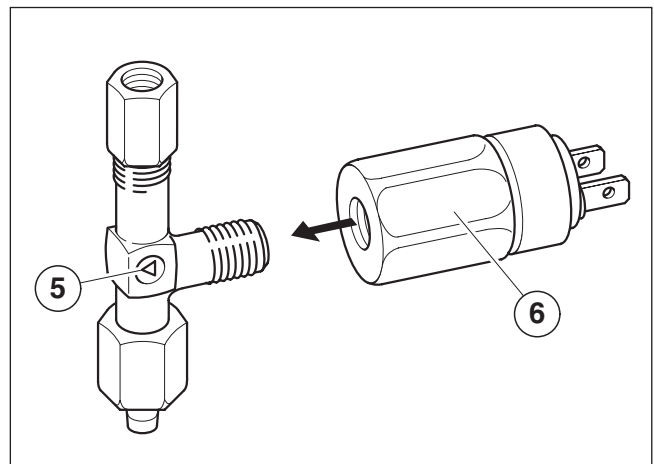

NOTE

A CS1200 ICL unit ordered from GHH RAND for external oil cooler operation is pre-equipped with the corresponding screw connections and oil pressure switch.

3.6.4 Mounting the air intake filter

The air filter for the compressor and available from GHH RAND must be suitably dimensioned with regard to the noise emission and filter capacity of the application on the silo vehicle.

When selecting air filters or combined intake silencers not supplied by GHH RAND, observe the following:

- Overall degree of separation η :
 η SAE roughly $\geq 99.5\%$
 Rated flow in accordance with the intake volume flow of the respective type of screw compressor.
- A paper filter should be selected as the filter material.

NOTICE

FILTER MATERIAL AND FILTER DESIGN UNSUITABLE!

Unsuitable filter material, as well as an insufficiently dimensioned filter can result in destruction of the screw compressor.

- ▶ Only use paper filter with the specified degree of separation.
- ▶ The max. permitted intake negative pressure is 65 mbar.

- ▶ The suction silencer/filter must be reliably protected against ingress of water (e.g. spray) and greater quantities of dirt.

NOTICE

INCORRECT INSTALLATION OF THE AIR INTAKE!

Damage due to the temperature and contamination of the goods to convey can occur if the air intake is located in the area of warm air or the discharge of hot exhaust gases.

- ▶ The air intake must not be located in the area of warm air or emitted hot exhaust fumes.
- ▶ If necessary, the exhaust system of the vehicle or the installation location of the air filter must be moved.

3.6.5 Mounting the discharge silencer

CAUTION

NOISE GENERATION!

Excessive noise exposure can lead to health problems.

- ▶ A discharge silencer is used to reduce the noise level. Further measures for reducing the noise level on the system side are recommended.
- ▶ During operation, always wear suitable ear protection.

If using a discharge silencer with damping material, make sure that the damping material cannot ingress into the conveying air.

Damping material made from stainless steel ensures this long-term. GHH RAND supplies effective discharge silencers without damping material.

Install the discharge silencer directly on the pressure flange.

The nominal width of the exhaust must not be reduced (increased noise emission, pressure loss).

WARNING

DANGER OF BURSTING!

An incorrectly dimensioned discharge silencer can burst or result in damage to the compressor due to the temperature.

- ▶ When selecting and designing the discharge silencer, make sure that it features a minimal pressure loss.
- ▶ The silencer must be suitable for the pressures used.

Mounting the discharge silencer CS1200 LITE

- ▶ Remove protective plugs from the threaded hole (3) on the discharge silencer (2) and screw the safety valve (1) firmly into the threaded hole.

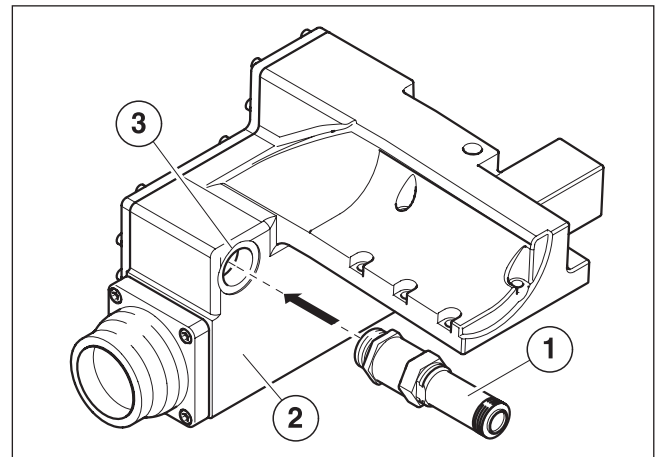

- ▶ Remove the protective film from the pressure flange (4) of the compressor (6).
- ▶ Place the discharge silencer (2) with flat seal (5) on the pressure flange (4) and fasten with screws (9 - 11) and wedge locking washers (8).
- ▶ Heed various lengths of the screws (9 - 11):

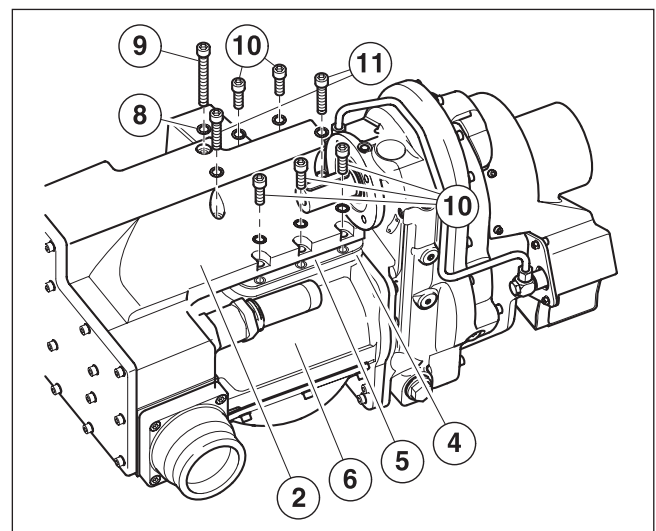

Pos. no.	Screw
9	M12×100
10	M12×35
11	M12×55

Tightening torque (A2-70): 65 Nm

- ▶ Place washers 13×18×8 (12) in the depressions (11) in the compressor housing.
- ▶ Insert the brackets (13) as shown and fasten with screws M12×30 (15) and plain washers (14) on the compressor housing.

Tightening torque (M12 A2-70): 65 Nm

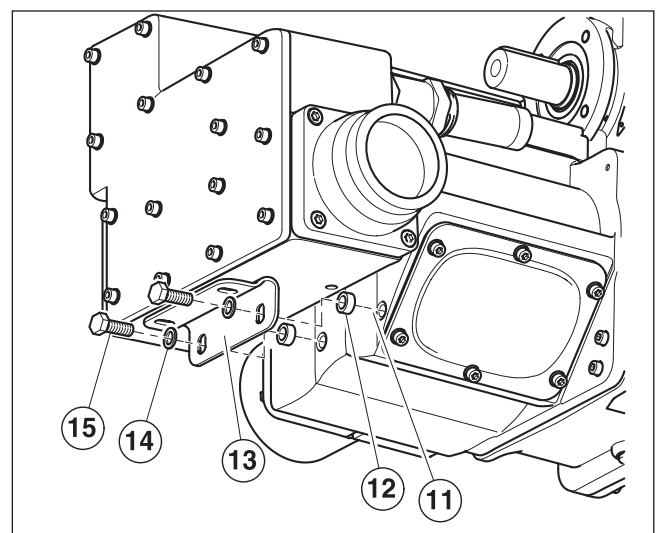

- ▶ Fasten brackets (13) with screws M10×25 (16) and plain washers (14) on the discharge silencer (2).
Tightening torque (M10 A2-70): 37 Nm

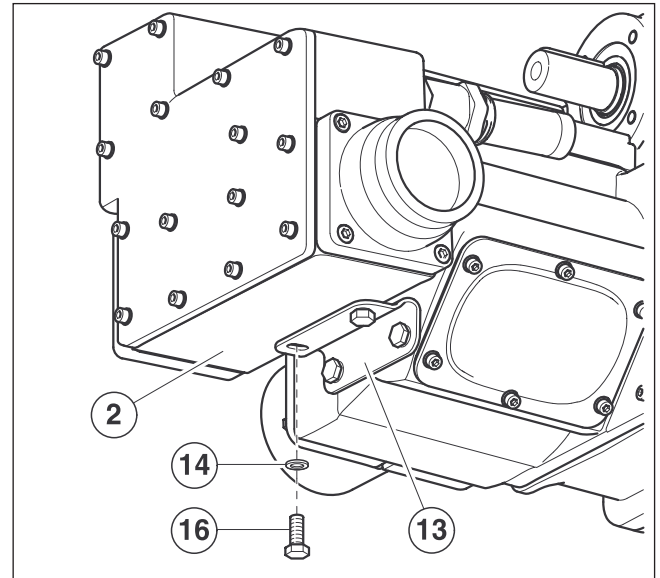

Alternative mounting of the pressure joint

If necessary, the pressure joint can also be mounted on the opposite side of the discharge silencer.

- ▶ Unscrew the cover (8) with seal (7).
- ▶ Unscrew the pressure joint (3) on the opposite side and carefully remove from the discharge silencer (6), remove the non-return flap (5) and seals (4) carefully from the discharge silencer flange.

NOTE

Dispose of removed seals; use only new seals for installation.

- ▶ Fasten components on the other side as depicted and secure with screws and split washers. Tighten the screws by hand, then tighten by tightening the screw opposite with the specified torque.

Tightening torque hose connector fitting (3), (M10 A2-70): 25 Nm

Tightening torque cover (8), (M10 A2-70): 37 Nm

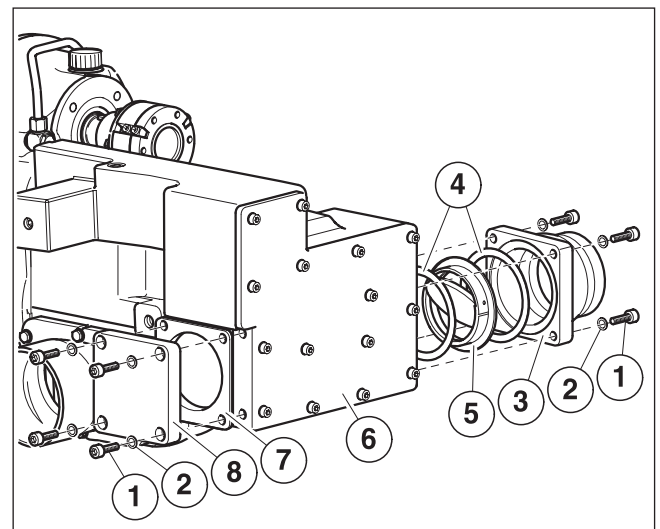

NOTICE

DAMAGE DUE TO INCORRECTLY INSTALLED NON-RETURN FLAP!

Improper assembly can cause damage.

- ▶ When reassembling, always use new seals.
- ▶ Never operate the compressor unit without a non-return flap.
- ▶ Pay attention to the proper installation position of the non-return flap. The side marked with "TOP" must point upwards.

CAUTION**HOT SURFACES!**

During operation, the screw compressor and discharge silencer are very hot. There is a risk of burning.

- ▶ Appropriate measures to screen the hot surfaces must be taken by the installation manufacturer.

3.6.6 Installing the safety valve**NOTE**

When installing a safety valve, observe the manufacturer instructions.

The safety valve (overpressure valve) is used as a safety mechanism for the compressor.

In order to prevent the operating pressure from increasing to impermissible levels, it should be of an encapsulated design.

NOTICE**IMPERMISSIBLE OPERATION OF THE SAFETY VALVE!**

There is a risk of damage to the compressor if the safety valve is operated as a discharge/control valve.

- ▶ Do not use the safety valve as a discharge/control valve.

When using discharge silencers not supplied by GHH RAND, observe the following:

The safety valve **(1)** must be installed close to the pressure joint and between the screw compressor and the non-return valve/non-return flap, e.g. in the discharge silencer **(2)**.

The permitted response pressure of the safety valve can be a maximum of 0.1 bar more than the max. operating pressure.

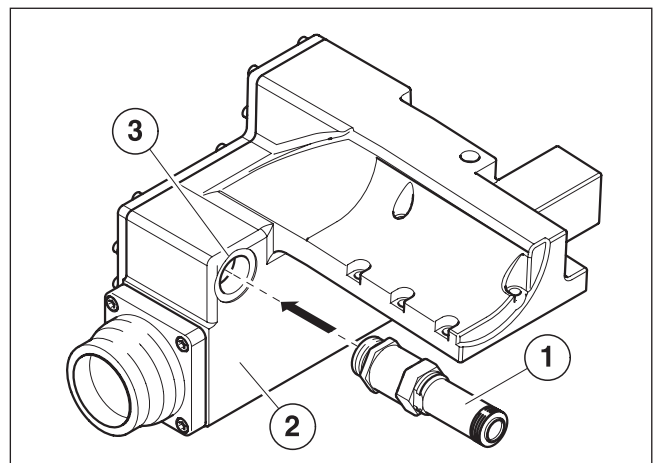
**NOTICE****INCORRECT DIMENSIONING OF THE SAFETY VALVE!**

An incorrectly dimensioned safety valve can result in damage to the compressor.

The safety valve must be dimensioned so that, in the event of a blockage in the line (e.g. jammed non-return valve), the air volume flow on the pressure side can be reliably discharged.

- ▶ The permitted response pressure must not be exceeded.

The safety valve from GHH RAND must only be installed as illustrated (0° ... 90°):

NOTICE

INCORRECT INSTALLATION POSITION OF THE SAFETY VALVE!

An incorrect installation position of the safety valve can result in destruction of the compressor.

- ▶ The safety valve must only be installed at an angle of 0° (vertical) to 90° (horizontal).

3.6.7 Mounting the non-return flap

To protect the compressor, a non-return valve (or non-return flap) must be installed in the pressure line, close to the compressor.

The non-return valve (or non-return flap) should prevent the compressor from running backwards for a long time. It is not used to prevent material blow-backs.

The discharge silencers supplied by GHH RAND have an integrated non-return valve (or an integrated non-return flap).

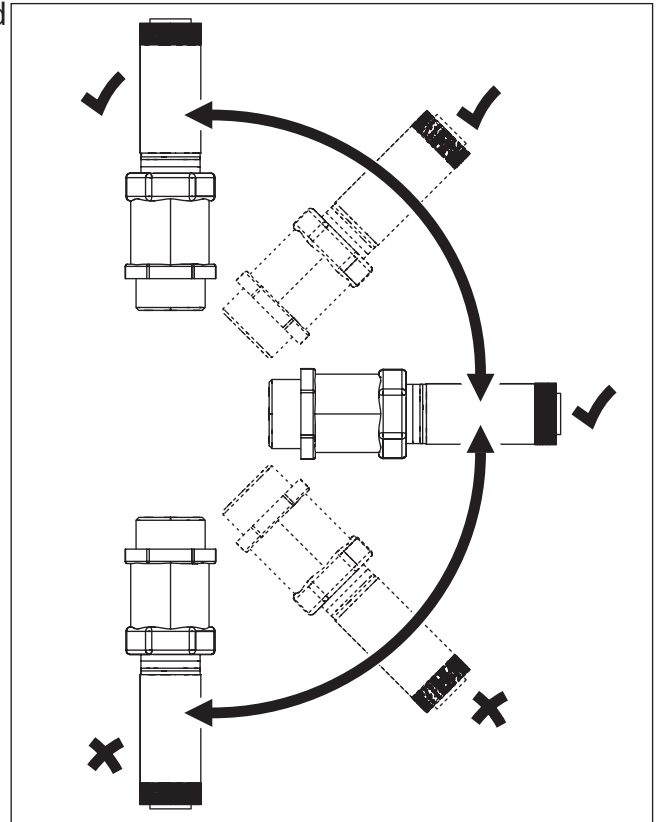

NOTE

To prevent unintended material rebound, it is obligatory to install an additional non-return valve (or a non-return flap) in the pneumatic system of the silo construction.

3.6.8 Installing the overload coupling

NOTICE

DAMAGE TO THE COMPRESSOR DRIVE SHAFT BEARING!

A coupling flange driven in with a hammer can damage the overload coupling and bearing of the compressor drive shaft.

- ▶ Do not drive the coupling flange onto the compressor drive shaft with a hammer.
- ▶ Deburr the feather key if necessary.
- ▶ If necessary, warm the coupling flange up to approx. 80 °C and push quickly into the desired position on the compressor drive shaft with suitable protective gloves.

Shear bolt overload coupling

- ▶ Push the coupling flange (2) over the feather key (6) on the compressor drive shaft and secure with hexagon socket screw (3).
- ▶ Fasten the shear bolt overload coupling (1) on the coupling flange (2) with hexagon screws M8×25 (5) and split washers (4).

Tightening torque (M8 8.8): 25 Nm

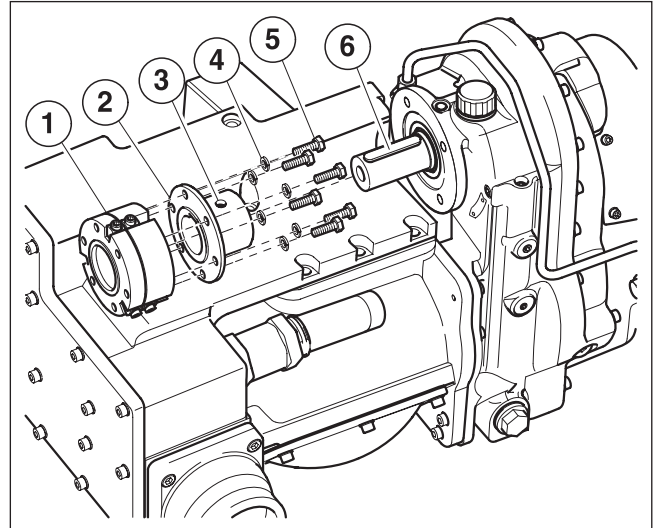

Friction overload coupling

- ▶ Remove the feather key (7) from the compressor drive shaft.
- ▶ Slide an additional sealing washer with O-rings (6) onto the compressor drive shaft.
- ▶ Reinsert the feather key (7) into the compressor drive shaft.
- ▶ Unscrew the threaded plug (1) with inserted O-ring (2) from the friction overload coupling (5).
- ▶ Unscrew the clamping bolt M12x45 (3) and clamping sleeve (4) from the overload coupling.
- ▶ Move the overload coupling over the feather key on the compressor drive shaft, insert the clamping sleeve and fix it to the compressor drive shaft using the clamping bolt.

Tightening torque (M12 8.8): 60 Nm

- ▶ Seal the overload coupling (5) with threaded plug (1) with inserted O-ring (2). In addition, screw a threaded plug with a face pin wrench (35x5 mm) in flush to the overload coupling.

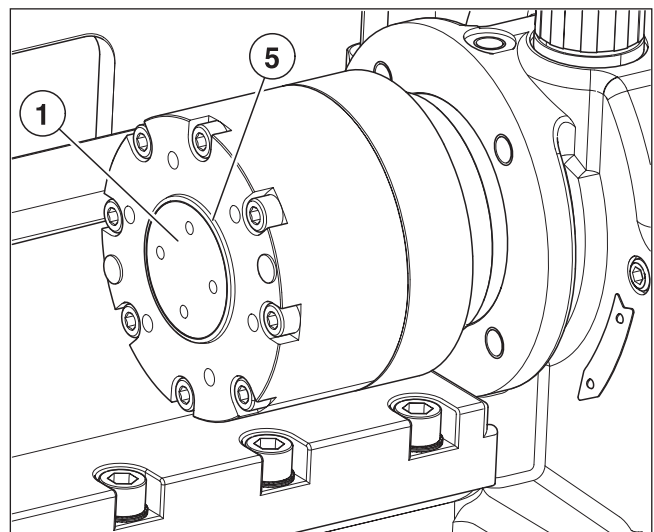
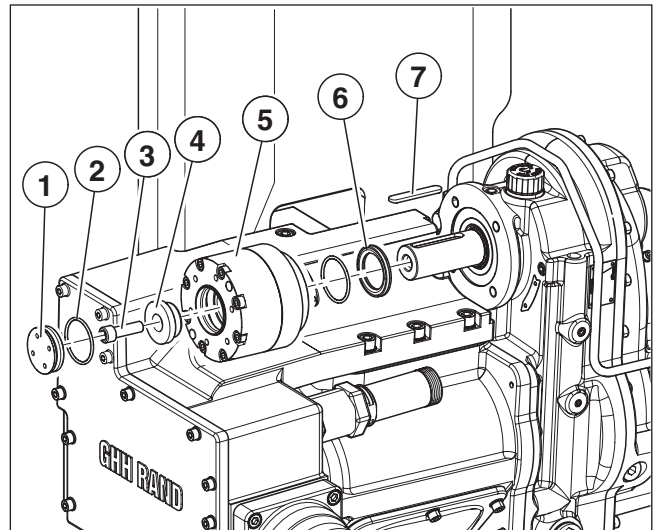

NOTICE

IMPAIRMENT OF THE SLIP FUNCTION OF THE OVERLOAD COUPLING!

A threaded plug that is screwed in too deeply, puts pressure on the clamping sleeve and affects the slip function of the friction overload coupling.

- ▶ Only screw the threaded plug in **flush** to the overload coupling.

NOTE

The threaded plug is provided with screw locking paste. This must not be reused after dismantling; only use a new threaded plug.

NOTE

The screw depth for the articulated shaft fastening screws must be max. 12 mm.

3.6.9 Installing the screw compressor on the mounting console (third-party manufacturer)

- ▶ Install the screw compressor on the mounting console taking the installation position into account (*Chapter 3.3 on page 20*).

At least three fastening screws (min. screw size: M16 10.9, hexagon screw with shaft) must be used.

- ▶ First tighten the fastening screws cross wise by hand.
- ▶ Tighten the fastening screws to the required tightening torque.

Tightening torque (M16 10.9): 279 Nm

⚠ WARNING

INCORRECT TIGHTENING TORQUE OR WRONG SCREW TYPE OR STRENGTH CLASS!

An incorrect tightening torque or the wrong screw type or strength class can endanger the secure attachment of the screw compressor, or result in damage to components due to excessive tightening torque.

- ▶ The specified tightening torques must be observed.
- ▶ Use the screws provided.

3.6.10 Installing the pressure line

Avoid reducing the nominal diameter of the outlet. The pressure line must be routed to the consumer as straight as possible and so that it is not under tension.

To prevent impact sound from being transferred and pipelines from moving between the discharge silencer and the subsequent pressure line, install a temperature-resistant expansion joint.

NOTE

When installing seals, fittings and flexible pipelines, make sure that the components have the appropriate thermal stability.

⚠ DANGER

RISK OF EXPLOSION!

The pressure line must be designed (geometry/material) so that the hot compressed air cannot ignite the conveyed material. In accordance with the professional association regulation BGI 666, for the pneumatic transport of materials subject to dust explosion, a temperature limit of max. 120 °C must be adhered to (measurement point before contact with the materials to be conveyed). It is therefore advisable to use a compressed air aftercooler to ensure a suitable conveying air temperature within the pneumatic system.

- ▶ Do not exceed the temperature limit at the measurement point before contact with the materials to be conveyed.

3.7 Completion of the compressor unit

3.7.1 Test mounting of the CS1200 LITE compressor kit

To determine the exact installation position on the vehicle frame and the fastening bores in the assembly console, it is necessary to position the compressor on the vehicle frame with the assembly console. It must be checked in this installation position whether all attachment parts can be mounted without problem and in accordance with the installation guidelines.

NOTE

It may be necessary to install lines, hoses, etc. fastened on the vehicle frame once again before mounting the compressor unit. The vehicle frame must remain free at the planned attachment location of the compressor unit.

- ▶ Mount the mounting console **(1)** on the compressor **(2)** by hand with 3 screws M16×35 10.9 **(4)** and wedge locking washers **(3)**.

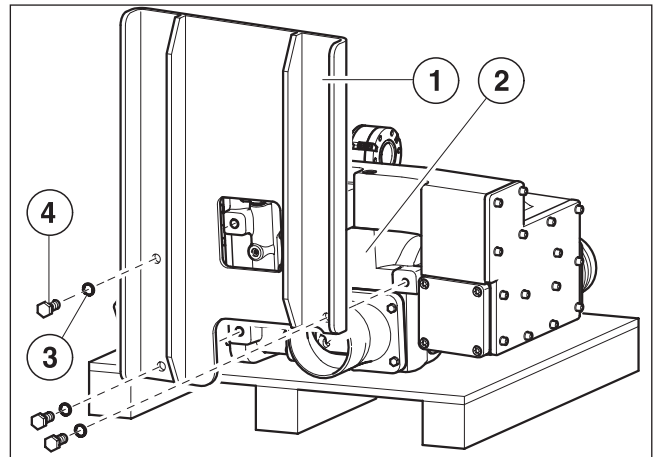

- ▶ Place the wooden slats or similar **(5)** under the discharge silencer so that the mounting console **(1)** is initially at a right angle to the vehicle frame **(6)**. Thus an angling of the drive flange of 3° is achieved (see *Chapter 1.8 on page 12*).

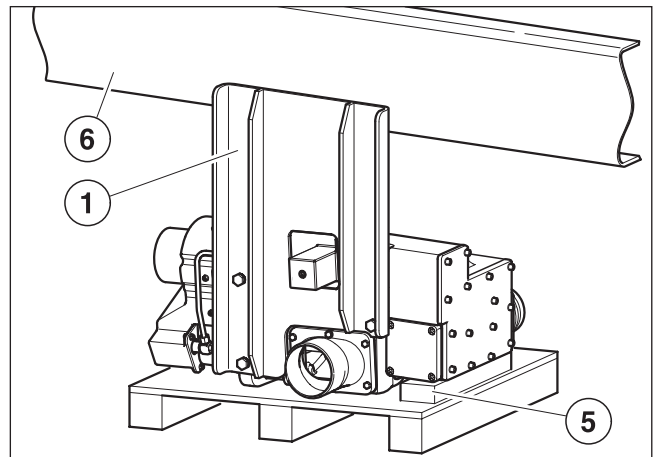

NOTE

In order to achieve parallel alignment of the flange, the mounting console must be aligned according to the vehicle frame (see *Chapter 3.4.3 on page 21*).

- ▶ Using a forklift or lifting truck **(8)**, drive the pallet **(7)** with the compressor carefully under the vehicle frame **(6)** until the mounting console **(1)** lies on the vehicle frame **(6)**.
- ▶ Lift the pallet **(7)** with compressor carefully until the desired installation position is reached. Here, make sure that the compressor does not touch the vehicle frame **(6)**.

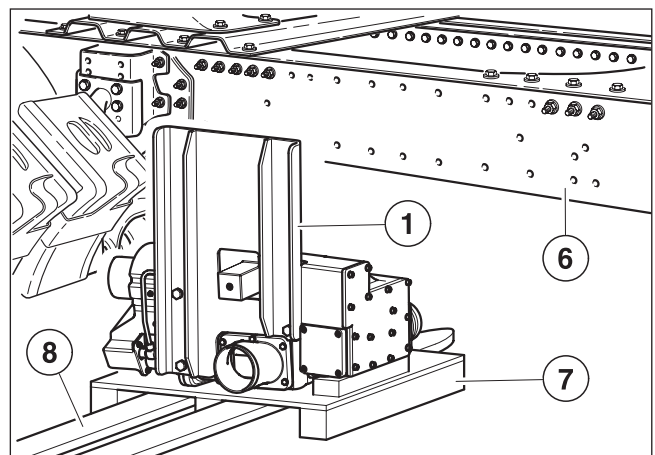

NOTE

The upper edge of the mounting console should be at least at the height of the upper edge of the vehicle frame.

- Make sure there is sufficient floor space for a full load.

If the compressor cannot be lifted high enough due to insufficient distance to the vehicle frame, it is possible to use - depending on requirements - 1 to 2 spacers (9) (optionally available as a kit) (thickness: 10 mm) between the mounting console (1) and compressor (2).

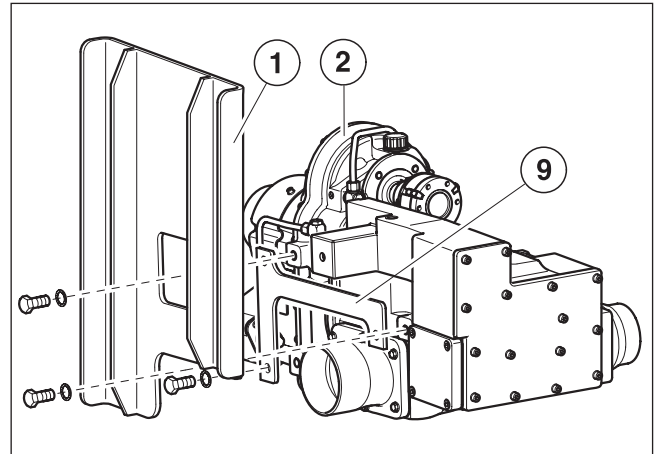

NOTE

If spacers are used, for one spacer the 45 mm screws contained in the kit must be used to fasten the mounting console on the compressor; for two spacers, the 55 mm screws must be used to fasten the mounting console on the compressor.

NOTE

A maximum of 2 spacers may be used. When replacing screws, pay attention to the correct length and strength class.

- **Tightening torque (M16 10.9): 279 Nm**

NOTE

If the compressor unit should be mounted so high that the mounting console protrudes over the vehicle frame, the mounting console can be shortened above accordingly.

NOTE

Compressor stage components may not touch the vehicle frame.

Once you have determined the correct installation position, the holes for the mounting of the mounting console on the vehicle frame should be determined as follows:

- For a pre-drilled vehicle frame (6) transpose the drill pattern of the vehicle frame (6) to the backside of the mounting console (1). At the same time, ensure that the reinforcement bar (10) on the mounting console is not drilled into.

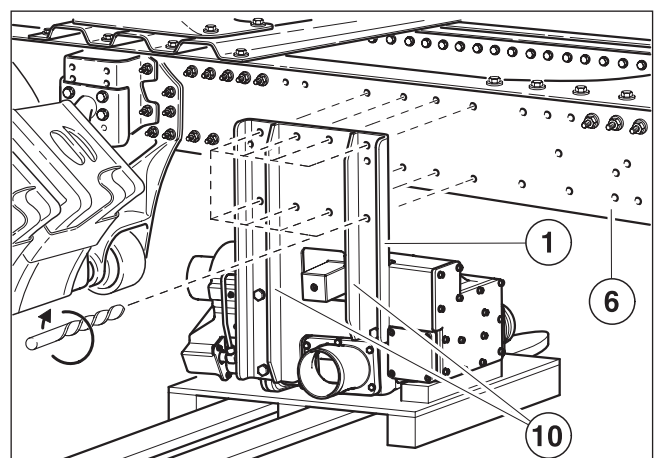

NOTICE**SUFFICIENT DIMENSIONING OF THE DRILL HOLES!**

Fit the mounting console with at least eight drill holes Ø 14.5 mm (min. screw size: hexagon screw with shaft M14 10.9 with the corresponding washer and self-locking nut).

- ▶ Preferably use the screw connections recommended by the vehicle manufacturer for load-bearing frame mounts.
 - ▶ The placement of the hole pattern can be different based on the respective vehicle frame. Use the largest hole spaces.
- ▶ If the vehicle frame has not been (sufficiently) pre-drilled, you must first drill holes into the vehicle frame based on the construction guidelines of the manufacturer as well as the dimensions of the mounting console. Transpose the hole patterns of the vehicle frame onto the backside of the mounting console.

NOTICE**INSUFFICIENT REINFORCEMENT OF THE ATTACHMENT AREA!**

The compressor unit can fall down due to insufficient reinforcement and cause damage to the frame (cracking).

- ▶ Reinforce some vehicle frames where the compressor unit is fitted in accordance with the manufacturer's installation guidelines.

NOTE

Compensate for any frame inclination, frame drop or auxiliary frame by using a special adapter, shim or chocks.

Special adapters can be obtained from GHH RAND for various vehicle types. For more information, please contact GHH RAND.

NOTICE**DAMAGE TO THE VEHICLE FRAME!**

The vehicle frame warps or is damaged.

- ▶ Welding work must not be performed on the vehicle frame.
 - ▶ Holes must only be drilled in the vehicle frame in accordance with the instructions in the manufacturer's installation guidelines.
- ▶ Lower the pallet and remove the compressor from the vehicle.
- ▶ Remove the mounting console from the compressor.
- ▶ Drill holes for the fastening screws into the mounting console in accordance with the markings.

3.7.2 Test mounting of the CS1200 ICL compressor unit

To determine the exact installation position on the vehicle frame and the fastening bores in the adapter, it is necessary to position the compressor unit with adapter on the vehicle frame with the assembly console. It must be checked in this installation position whether all attachment parts can be mounted without problem and in accordance with the installation guidelines.

NOTE

The unobstructed outlet of cooling air must be guaranteed for the compressor unit (*Chapter 3.4.4 on page 22*).

NOTE

It may be necessary to install lines, hoses, etc. fastened on the vehicle frame once again before mounting the compressor unit. The vehicle frame must remain free at the planned attachment location of the compressor unit.

NOTE

In order to achieve parallel alignment of the flange, the mounting console must be aligned according to the vehicle frame (see *Chapter 3.4.3 on page 21*).

- ▶ Using a forklift or lifting truck **(1)**, drive the pallet **(2)** with the compressor unit carefully under the vehicle frame **(3)** until the adapter **(4)** lies on the vehicle frame.
- ▶ Lift the pallet **(2)** with compressor unit carefully until the desired installation position is reached. Here, make sure that the compressor unit does not touch the vehicle frame **(3)**.

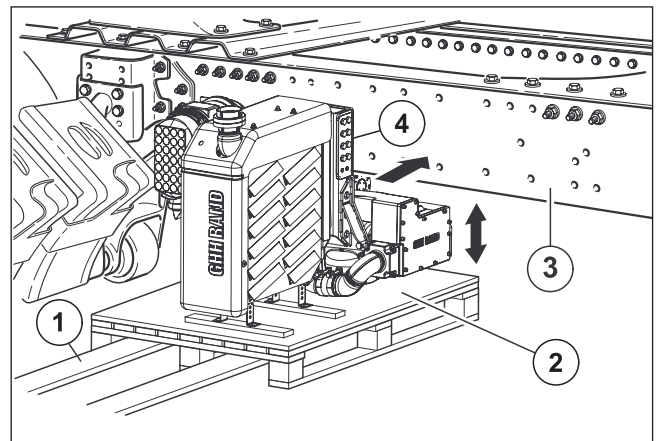

NOTE

The upper edge of the adapter should be at least at the height of the upper edge of the vehicle frame. In order to achieve an offset, the adapter can be dismantled, turned by 180° and remounted. Make sure there is sufficient floor space for a full load.

NOTE

If vehicle parts prevent the compressor unit from being mounted, the compressor stage should be brought to the installation position separate from the Intercooler.

NOTE

Compressor stage components may not touch the vehicle frame.

Once you have determined the correct installation position, the holes for the mounting of the adapter on the vehicle frame should be determined as follows:

- ▶ For a pre-drilled vehicle frame, transpose the drill pattern of the vehicle frame **(3)** to the backside of the adapter **(4)**.

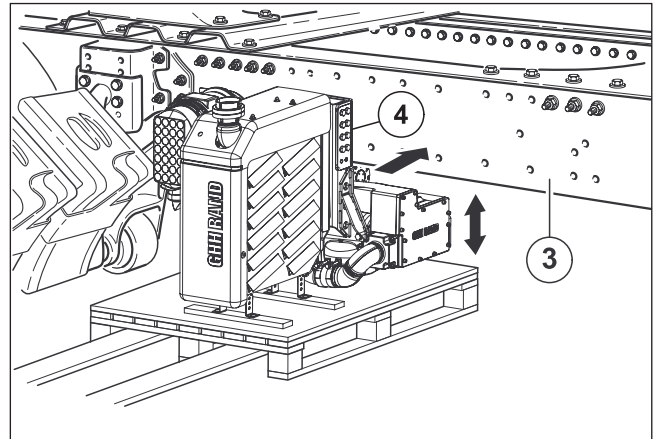

NOTICE

SUFFICIENT DIMENSIONING OF THE DRILL HOLES!

Fit the adapter with at least eight drill holes \varnothing 14.5 mm (min. screw size: hexagon screw with shaft M14 10.9 with the corresponding washer and self-locking nut).

- ▶ The screw connections recommended by the vehicle manufacturer for load-bearing frame mounts should preferably be used.
- ▶ The placement of the hole pattern can be different based on the respective vehicle frame. Use the largest hole spaces.

- ▶ If the vehicle frame was not drilled (sufficiently) at the factory, initially drill holes according to the vehicle manufacturer's installation guidelines and the dimensions of the adapter on the vehicle frame. Transpose the hole patterns of the vehicle frame onto the backside of the adapter.

NOTICE

INSUFFICIENT REINFORCEMENT OF THE ATTACHMENT AREA!

The compressor unit can fall down due to insufficient reinforcement and cause damage to the frame (cracking).

- ▶ Reinforce some vehicle frames where the compressor unit is fitted in accordance with the manufacturer's installation guidelines.

NOTE

Compensate for potentially existing slopes of the frame, an off-set frame or auxiliary frame by using a base plate or wedges.

Special adapters can be obtained from GHH RAND for various vehicle types. For more information, please contact GHH RAND.

NOTICE

DAMAGE TO THE VEHICLE FRAME!

The vehicle frame warps or is damaged.

- ▶ Welding work must not be performed on the vehicle frame.
- ▶ Holes must only be drilled on the vehicle frame in accordance with the instructions in the manufacturer's installation guidelines.

- ▶ Lower the pallet and remove the compressor unit from the vehicle.
- ▶ Loosen the screws (5) remove the adapter (4) from the console (6).
- ▶ Drill holes for the fastening screws according to the markings on the adapter (4).

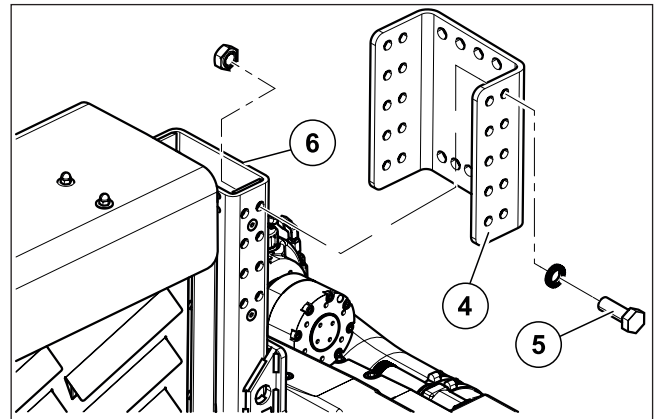

3.7.3 Mounting of the CS1200 LITE compressor kit

- ▶ Fasten the mounting console to the compressor again as determined in the test mounting (*Chapter 3.7.1 on page 34*).
- ▶ Lift pallet with compressor using a fork lift or lifting truck and align according to the fastening holes on the vehicle frame and the mounting console.
- ▶ Screw the mounting console (1) to the vehicle frame (2) using screws (3).
- ▶ Tighten the fastening nuts on screw connection (3) with the specified tightening torque.
Tightening torque (M14 10.9): 193 Nm

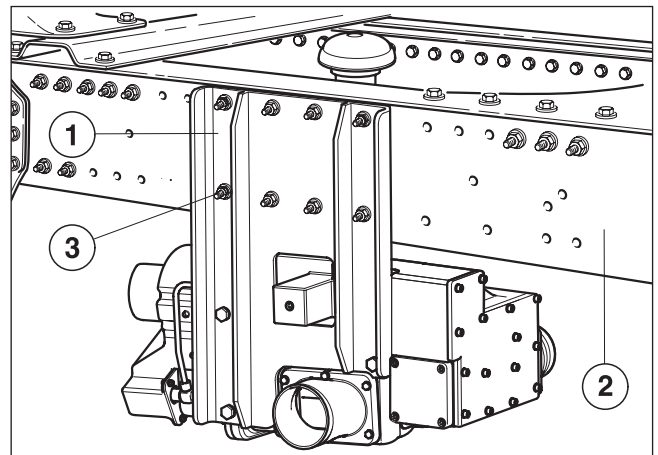

NOTE

It may be necessary to attach a heat protection plate to protect electrical/pneumatic lines near the discharge silencer.

- ▶ Lower the pallet and remove the fork lift or lifting truck.
- ▶ Fasten the rain cap (1) on one point within the vehicle frame where the coldest, cleanest air is drawn in.

NOTICE

INCORRECT INSTALLATION POSITION OF THE AIR INTAKE OIL COOLER FAN!

If the fresh air supply to the oil cooler fan is restricted, is located in the area of warm air or dirt gets into the oil cooler, temperature damage to the compressor could occur.

- ▶ Ensure sufficient fresh air supply.
- ▶ Do not operate the compressor without an air intake oil cooler fan.
- ▶ The air intake must not be located in the area of warm air (e.g. exhaust air from the engine).

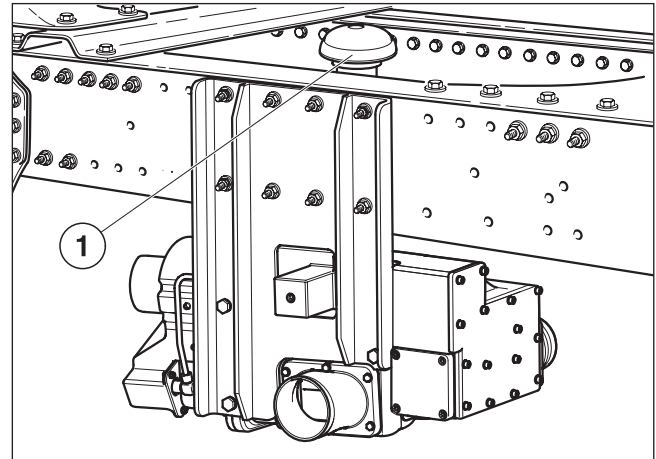

- ▶ Fasten the NW125 spiral hose to the rain cap fitting with hose clamps.
- ▶ Fasten the spiral hose (3) to the intake fitting of the oil cooler fan with the hose clamp (2).

NOTE

Install the hose line so that it does not touch any turning or hot parts.

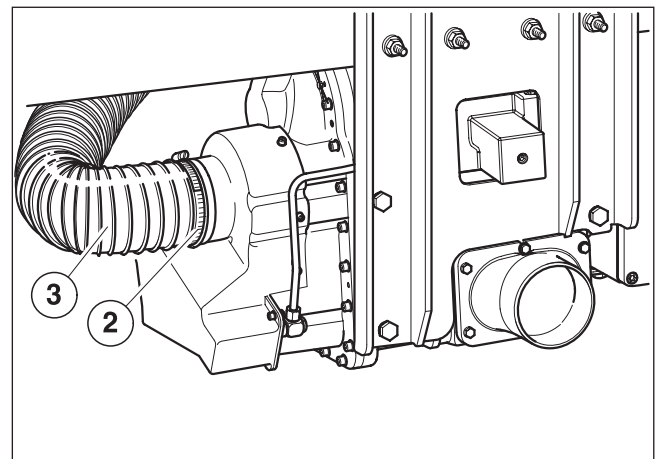

- ▶ Fasten the maintenance indicator (1) and oil pressure gauge (2) to the holder (3) and the holder to the vehicle frame (4).

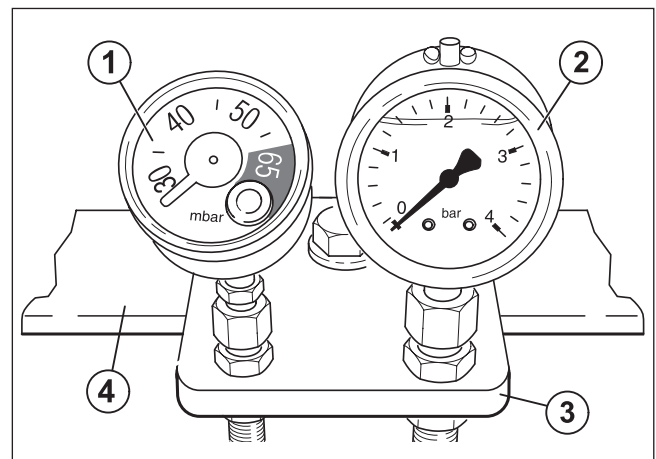

- ▶ Cut the pressure hose (12) to the required length and mount pipe fittings (9) on both ends. Hold the end of the hose fast with a clamping tongs and oil with spray oil. After that, screw the screw sleeve (11) onto the hose end (12) anticlockwise up to the stop (depth $d=17\text{ mm}$) and screw the pipe fittings (9) into the screw sleeve (11) clockwise up to the stop on the hexagonal bolt (10).

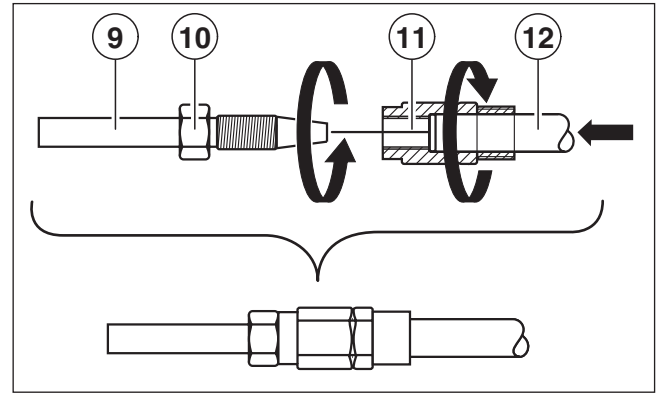

NOTICE

LEAKS AND BLOCKAGES IF THE MEASURING LINES ARE INSTALLED INCORRECTLY!

When screwing in the pipe fitting, make sure that the hose does not slip out of the screw sleeve. Only with correct mounting is the leak tightness guaranteed. After correct installation, check the line for flow.

- ▶ Position the pipe fitting correctly and align it with the screw sleeve. When screwing it in, make sure that the hose does not slip out of the screw sleeve.
- ▶ Check the flow using compressed air.

- ▶ Connect the vacuum hose line (17) with the mounted pipe fittings to the maintenance indicator (13) and to the pipe connector (7) (see *Chapter 3.6.2 on page 25*).
- ▶ Connect the oil pressure hose (15) to the oil pressure gauge (14) and to the previously-mounted screw connector on the compressor (see *Chapter 3.6.2 on page 25*).

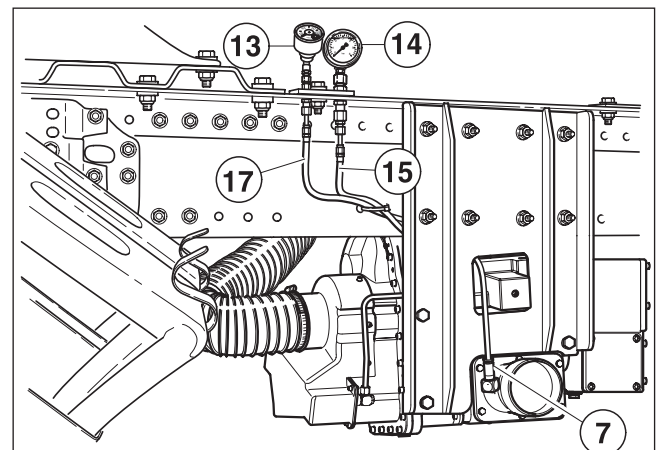

- ▶ Mount the air intake filter (1) in a suitable place on the vehicle with 2 holders (3).
- ▶ Mount the hose (2) on the air filter housing with hose clamp.

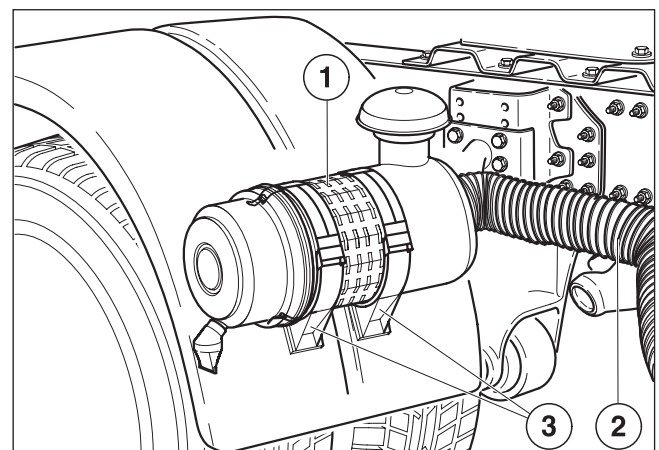

- ▶ Mount the hose (2) on the hose connector flange (5) of the compressor with hose clamp (4).

NOTE

Install the hose line so that it does not touch any turning or hot parts.

To avoid kinks in the hose due to small radii, there is a 90° angle (incl. pipe and 2 hose clamps) included in the scope of delivery; it can be mounted on the air filter housing or on the hose connector flange of the compressor.

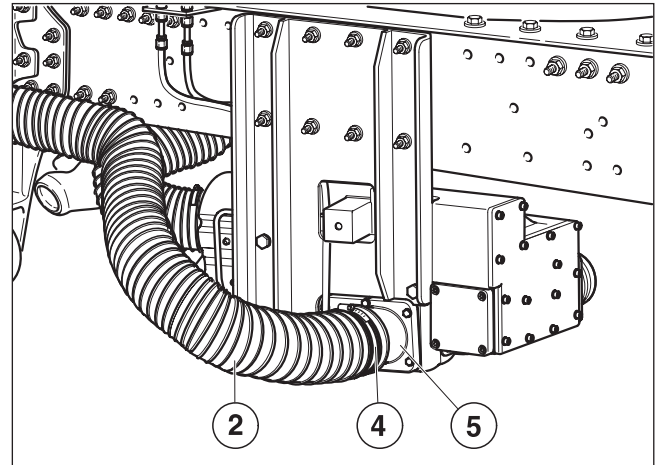

3.7.4 Mounting of the CS1200 ICL compressor unit

- ▶ Attach the adapter to the vehicle frame as determined in the trial installation (see *Chapter 3.7.2 on page 37*).
- ▶ Screw the adapter (1) to the vehicle frame (2) using screws (3).

Tightening torque (M14 10.9): 193 Nm

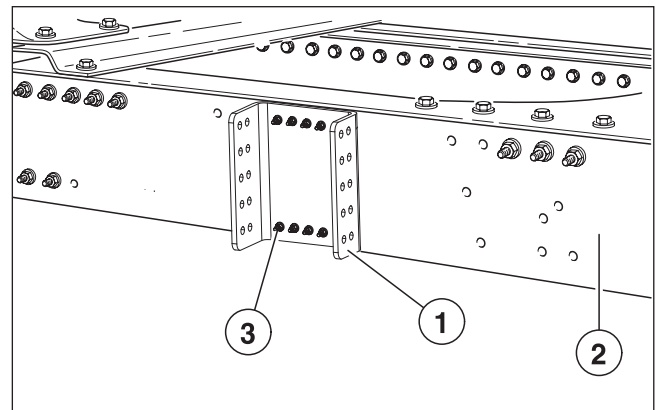

- ▶ Lift the pallet (6) with the compressor using a forklift or lifting truck (7).
- ▶ Align the compressor unit with the console (5) in the adapter (1) which was previously fitted to the vehicle frame.
- ▶ Check the alignment according to the installation guidelines.

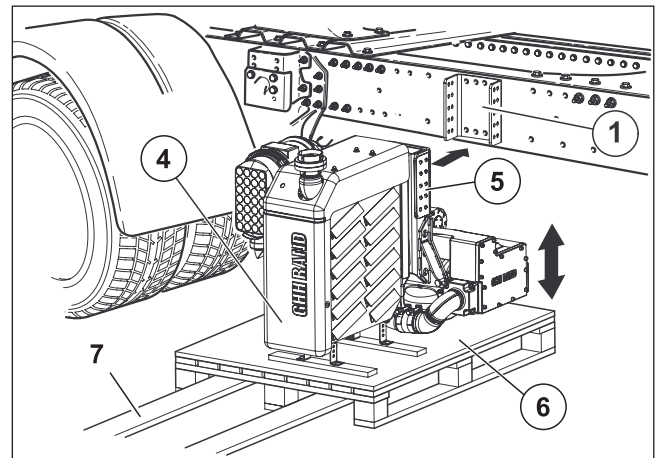

- ▶ After aligning the console (5) of the compressor unit (4), screw it to the adapter (1) with eight screws (8) M14x40, strength class 10.9 with wedge locking washers (9) and nuts (10), on both the left and right.

Tightening torque (M14 10.9): 193 Nm

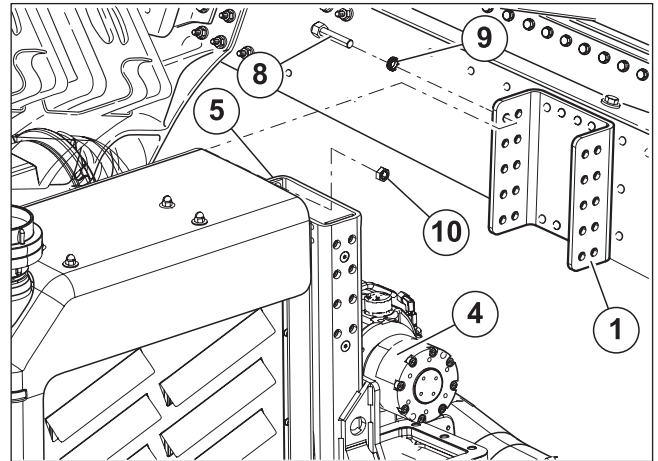

- ▶ Separate the compressor unit (4) from the pallet (6) by unfastening the four screw connections (11).

⚠ CAUTION

RISK OF CRUSHING!

There is a risk of crushing if the compressor unit falls down.

- ▶ Support the pallet with the lift truck or forklift until the four screw connections have been unfastened and removed from the pallet.

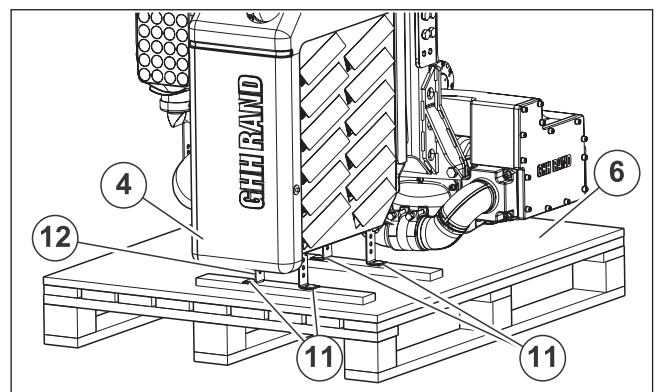

- ▶ After the four screw connections (11) have been unfastened, lower the pallet and then remove the fork lift or lift truck.
- ▶ Connect the hose to the air intake filter and the air intake oil cooler fan to the compressor, attach them to the vehicle frame using the holders and clamps provided and mount the rain cap, see *Chapter 3.4.5 on page 23 and Chapter 3.7.3 on page 39*.

NOTE

For the fixed add-on structure, it is possible to use the upper internal pressure joint (2 1/2" female thread). For this, a corresponding hole must be made in the GFK cover. As it is not possible to install the non-return flap in this connection position, a non-return valve must be installed in the outgoing pressure line on the system side. The passage cross section must be chosen accordingly so that it is large enough (larger than the pipe cross section).

3.7.5 Installing the articulated shaft

CAUTION

RISK OF INJURY DUE TO ROTATING PARTS!

If the rotating parts are not adequately covered, there is a risk of injury.

- ▶ Provide a cover for the articulated shaft in accordance with accident prevention regulations.

- ▶ Screw the articulated shaft **(2)** to the vehicle's auxiliary drive flange **(1)** and to the overload coupling flange **(3)**.

Tightening torque (M8 8.8): 25 Nm

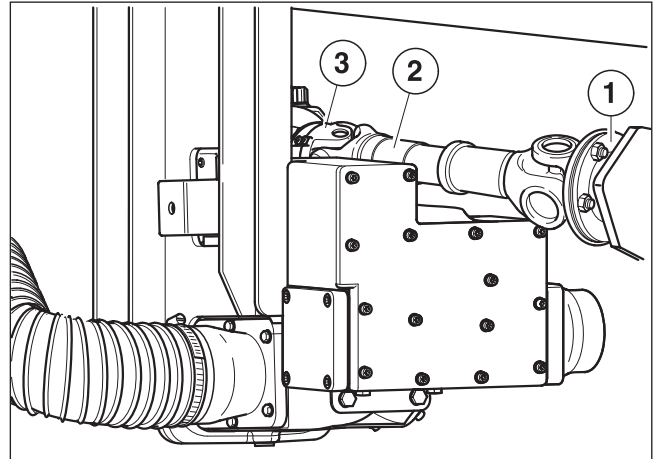

3.8 Connecting the external oil cooler to the CS104 L2/R2 compressor

NOTE

If the GHH RAND screw compressor or the compressor unit be operated under the conditions listed in *Chapter 1.13 on page 15*, a suitably selected oil cooler must be installed.

The oil cooler supply and return must be connected in accordance with the data given in *Chapter 1.7 on page 9* and *Chapter 3.6.3 on page 26*.

The erection of the cooler and the installation of the connection lines must be done so that when the screw compressor stops, the oil does not run back into the compressor.

The feed lines to the oil cooler must have the appropriate dimensions in order to ensure that there is sufficient pressure in the oil filter (minimum internal diameter of 10 mm).

The oil pressure gauge must be connected close to the compressor stage in the pipeline from the external oil cooler (*Chapter 3.6.3 on page 26* connection **(2)**).

3.8.1 Installing the external oil cooler fan controller (optional)

The cooling of the compressor is handled by an external oil cooler, whose fan is switched on by the controller as soon as a particular oil pressure is reached in the compressor.

NOTE

The electrical connection must only be carried out by qualified personnel.

- ▶ Observe the mounting instructions of the respective vehicle manufacturer and local guidelines and specifications.

NOTE

Depending on the model, 1 or 2 electric fans can be connected to the controller. These are switched in parallel, so the connection sequence plays no role.

- ▶ Unscrew the cover **(2)** of the fan controller **(1)**.
- ▶ Pre-drill holder for the housing of the fan controller according to the fastening holes **(3)** (dimensions: 67 × 146 mm).
- ▶ Fasten the housing of the fan controller to the holder with four M4 screws.
- ▶ Screw the cover back onto the housing.
- ▶ Connect plugs **(A/B/C)** of the fan controller as follows:

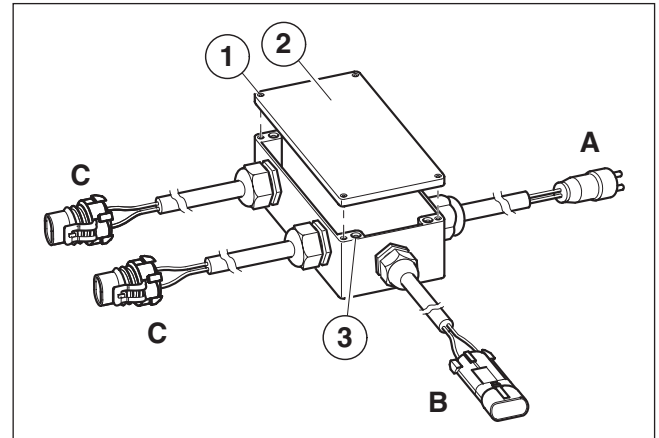

Plug	Identification/connection
A	OIL PRESSURE SWITCH: Oil pressure switch (<i>Chapter 3.6.3 on page 26</i>)
B	24 V DC: Vehicle power supply
C	FAN: Electric fan oil cooler

3.9 Connecting the control unit to the CS1200 ICL compressor unit

- ▶ Attach the control unit for supplying power for the cooling fan to the connection option for 24 V DC provided by the vehicle manufacturer.

The connection must be fused with at least 20 A. The compressor unit can either be connected to continuous or ignition voltage.

NOTE

The electrical connection must only be carried out by qualified personnel.

- ▶ Observe the mounting instructions of the respective vehicle manufacturer and local guidelines and specifications.

Compressor unit cable assignment

Pos. pole (+): blue cable or marked with (1)

Neg. pole (-): brown cable or marked with (2)

NOTE

- ▶ If the cooling fan is not running, check the cable for proper connection and polarity.

4 Safety labels

The safety labels must be attached by the installer of the system.

Apply maintenance instructions and lubricant recommendation (use the version in the local language of the operator)!

- ▶ Affix safety labels, maintenance instruction and lubricant recommendation to the relevant points of the installed compressor.
- ▶ Attach the second maintenance instruction where it can be clearly seen, e.g. in the driver's cab.
- ▶ Enter machine no. with waterproof pen.

NOTE

The areas that are to receive the stickers must be completely free of grease and dust!

- 1 Compressed air outlet/direction of flow
- 2 Hazardous electrical voltage (only for intercooler version)
- 3 Danger of burning! Hot surface
- 4 Do not enter
- 5 Read and follow the safety notes and operating instructions before starting operation
- 6 Wear hearing protection
- 7 Caution! No breathable air

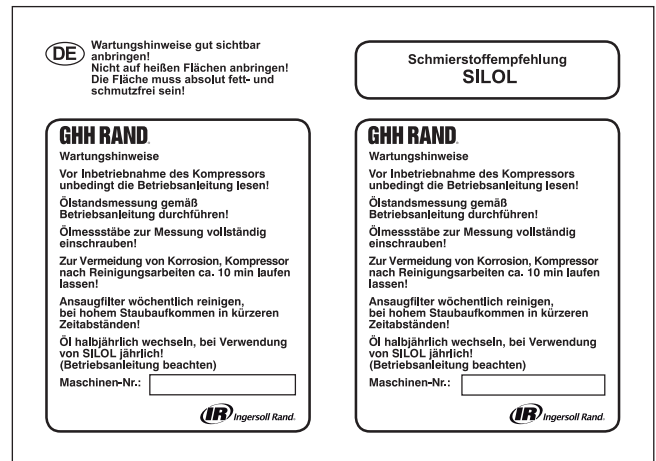
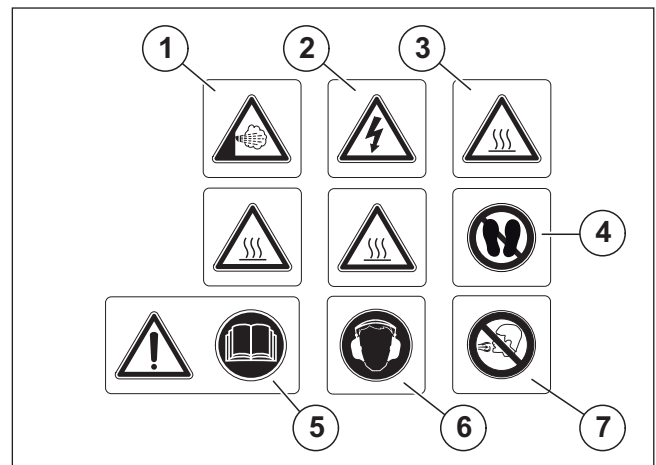

4.1 Attaching the stickers to the unit (example)

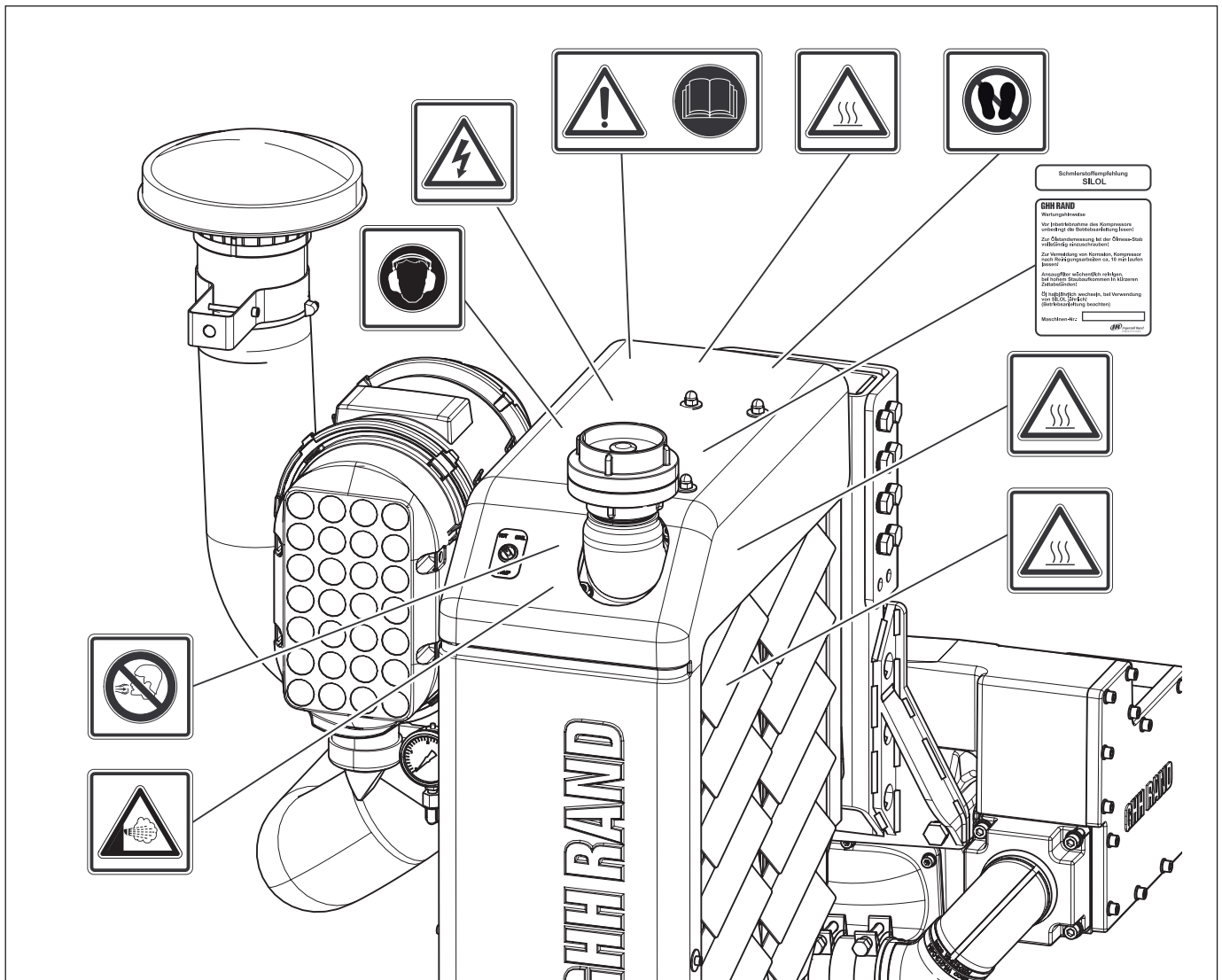

5 Initial commissioning

Initial commissioning is carried out by the installer of the system.

It includes filling with lubricant, removing the preservation, the test run with a check of the direction of rotation and speed, as well as the function control of the fan (IC units).

If in exceptional cases the first start of operation is carried out by the customer, the following work has to be carried out:

Work	Section
Filling with lubricant	5.2
Removing the preservation	5.3
Test run	5.4
Switching On	5.4.1
Checking the direction of rotation	5.4.2
Checking the drive speed	5.4.3
Cooling fan	5.4.4
Switching off	5.4.6
Checks after the test run	5.4.7

5.1 Lubricant

We recommend using our fully synthetic high-performance lubricant, Silol.

If you use exclusively Silol or Silol FG (foodgrade) the interval for an oil change **doubles** to a max. **12 months**. The period of the manufacturer's warranty for new compressor units **is extended to 2 years**.

NOTE

For recognition of the guarantee extension, proof of the maintenance interval using Silol or Silol FG is required.

Depending on the operating conditions, brand-name motor oils with API classification SJ/CF as per SAE J183 can also be used.

The respective viscosity class (SAE class) can be taken from the following diagram.

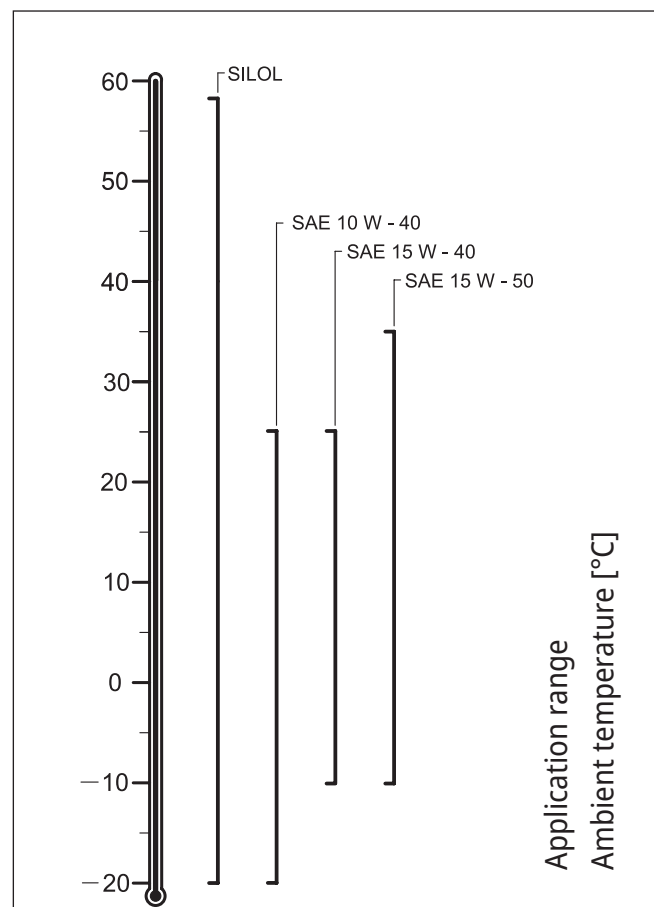

5.2 Filling with lubricant

NOTICE

DAMAGE DUE TO INCORRECT OILS!

Incorrect oils can destroy the compressor.

- ▶ Only use specified oil.

- ▶ Unscrew and remove the locking screw **(1)** from the compressor housing.
- ▶ Unscrew the cap **(3)** and top up with new oil according to the lubricant recommendation (*Chapter 5.1 on page 48*):
CS104/CS1200: approx. 3 litres
- ▶ After a short wait time, check whether the oil reaches the lower edge of the threaded hole **(2)** (see magnified view).
- ▶ Screw the locking screw **(1)** back in.
Tightening torque (M20x1.5): 70 Nm

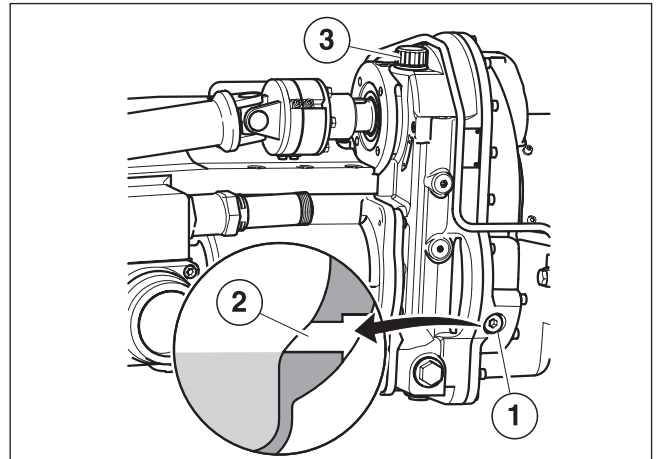

NOTE

Seal ring: DIN 7603 - A21x26 - soft iron.

- ▶ Screw the cap **(3)** back on.
- ▶ Make a note for the operator of the type of oil and the filling date.

5.3 Removing the preservation

To prevent corrosion, the screw compressors are provided with an anti-corrosive agent.

During initial commissioning, the anti-corrosive agent evaporates and is blown off when the screw compressor warms up.

NOTE

Do not begin conveying until the screw compressor anti-corrosive agent has evaporated.

5.4 Test run

CAUTION

HOT SURFACES!

During operation, the compressor and discharge silencer are very hot. There is a risk of burning.

- ▶ Wear protective gloves.

CAUTION

NOISE GENERATION!

An excessive acoustic pressure level can result in damage to hearing.

- ▶ Do not operate the compressor without the discharge silencer.
- ▶ During operation, always wear suitable ear protection.

CAUTION

ROTATING PARTS!

Insufficiently covered parts can lead to injuries.

- ▶ During the checks, sufficient distance must always be kept from rotating parts.

The rotation direction, the rotational speed, the cooling fan (IC unit) and the flawless function of the safety equipment must be checked during the test run.

Preparation

- ▶ Make sure that the compressor is filled with oil in accordance with the recommendation for lubrication. Observe the fill quantity.
- ▶ Check all safety-relevant screw connections for firm seating.
- ▶ Before the test run, re-parameterise vehicle engines with EDC control.

5.4.1 Switching on

NOTICE

RISK OF BLOWBACK OF MATERIAL!

If the compressor or compressor unit is started if there is counter pressure, there is a risk of damage to the non-return flap due to blowback of material.

- ▶ Only start the compressor or compressor unit when completely depressurised.
- ▶ Never go into operation against a potentially existing counter pressure.

- ▶ Switch on power take-off.

5.4.2 Checking the direction of rotation

- ▶ Check the direction of rotation. The compressor stage must turn facing the compressor drive shaft according to the arrow marking on the compressor housing.

5.4.3 Checking the drive speed

NOTICE

INCORRECT SPEED RANGE!

An incorrect speed range can destroy the compressor.

- ▶ Ensure that the compressor is only operated within its permissible rotational speed range.

- ▶ Check the drive speed of the screw compressor.
The speed must remain within the speed range for the screw compressor specified in the technical data.

5.4.4 Cooling fan CS1200 ICL

Check the correct direction of rotation of the fan.

- ▶ The fan must convey the flow of air from the inside to the outside **(1)**.
- ▶ A sheet of paper held in front of the fan screen with a running fan must be pushed away from it.

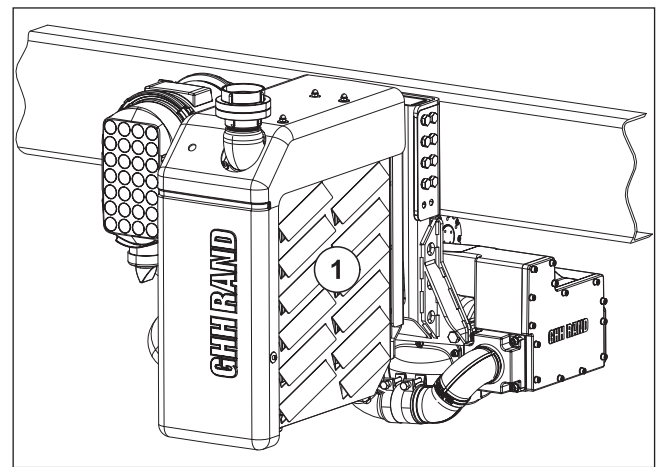

5.4.5 Function control of external oil cooler fan (CS104 L2/R2 compressor)

A sheet of paper held in front of the radiator of a running fan must be sucked towards it.

NOTICE

DAMAGE TO THE COMPRESSOR!

The compressor can be damaged if the fan is defective.

- ▶ Check that the fan works.
 - The paper is sucked in by the fan.

5.4.6 Switching off

NOTICE

RISK OF BLOWBACK OF MATERIAL!

If the compressor is switched off if there is counter pressure, there is the risk of damage to the non-return valve due to blowback of material.

- ▶ Do not switch off the compressor if there is counter pressure!
- ▶ If there is counter pressure, take appropriate measures to reduce pressure before switching off the compressor.

NOTE

The non-return flap installed in the compressor unit prevents the compressor from running backwards rapidly and for a long time (as a result of residual pressure in the compressed air lines of the pneumatic system) after being shut down.

To prevent unintended material rebound, an additional non-return valve (or non-return flap) must be provided in the pneumatic system of the silo construction.

- ▶ Switch off power take-off.

5.4.7 Checks after the test run

- ▶ Check all screws for firm seating.
- ▶ After the test run, check the oil level in the compressor and correct as required.

NOTICE

INSUFFICIENT LUBRICATION!

Too low an oil level can damage the machine.

- ▶ After the test run, especially for compressors with an external oil cooler, the oil level in the compressor must be checked again and if necessary, the oil topped up, since otherwise the oil level sinks due to the filling of the oil cooler and the oil lines from/to the oil cooler in the test run.
- ▶ If necessary, carry out further short test runs and check the oil level repeatedly.

Printed in Germany

Reserves the right to amend technical details compared to the information and illustrations of the operating manual. A replication, copying or translation, even in parts, is not permitted without written consent.

As a contribution to environmental protection:

This paper has been produced from 100% chlorine free bleached pulp.

GHH RAND®

Service & Support

www.ingersollrand.com/ghhrandtransport



Subject to revision without notice

Printed in Fed. Rep. of Germany

12/2022 EN